

Design and Performance Evaluation of a Solar Poultry Egg Incubator

Bukola Olalekan Bolaji

Department of Mechanical Engineering
University of Agriculture
P.M.B. 2240, Abeokuta, Nigeria.
E-mail: bobbolaji2007@yahoo.com

Abstract

In this study, a solar poultry egg incubator was designed, fabricated and tested to evaluate its performance. The incubator consists of a solar collector with built-in thermal storage and incubating chamber of 100 eggs capacity. During the incubating period, average outlet collector temperature of 72.4 °C was obtained on the highest solar radiation day and 51.8 °C was obtained on the lowest solar radiation day. The incubating chamber was maintained throughout the incubating period within a temperature range of 37.0 to 39.5 °C and relative humidity range of 58.0 to 71.5 %. The collector thermal efficiency was found to be 68.7 %. The percentage fertility and hatchability of eggs were 85.0% and 78.8 % respectively.

Keywords: collector, incubator, poultry, performance, solar energy.

1. Introduction

The continuous rise and competitive demands for fossil fuel necessitate the need for alternative source of renewable energy. In many parts of the world there is a growing awareness that renewable energy has an important role to play in extending technology to farmers in developing countries to increase their productivity. Solar thermal technology is a technology that is rapidly gaining acceptance as an energy saving measure in agriculture application. It is fast becoming an alternative source of energy because of the high rate of depletion of the conventional energy sources. It is preferred to other alternative sources of energy such as wind and shale, because it is abundant, inexhaustible, and non-polluting. It is capable of meeting a significant portion of the world's future energy needs with minimum of adverse environmental consequence [1-2].

Solar energy has been used for centuries by man for drying animal skins and clothes, preserving meat and fish, drying agriculture crops and evaporating sea water in order to extract salt [3-4]. Several investigators have recently studied various applications of solar drying. Thakur et al. [5] studied the heat transfer and friction factor correlations for packed bed solar air heater for low porosity system. Berinyuy [6] and Nasir [7] studied a solar tunnel

dryer for natural convection drying of vegetables and thermal performance of a parabolic cylindrical trough solar air heater respectively. Bolaji [8] investigated a box-type absorber solar air collector for crop drying. Waewsak et al. [9] studied a mathematical modeling of hot air drying for some agricultural products.

However, the application of solar energy in poultry production has not received comparable attention especially in the developing countries. Also, the poultry product requirements of these countries have not been sufficiently met. This calls for more efforts at encouraging the consumption of poultry in the developing countries. This can be achieved through active research in all area of poultry production including the development of efficient and energy saving but cheap equipment for poultry production such as incubators.

Incubation is an art of managing fertilized eggs to ensure the satisfactory development of embryo into a normal chick either by natural or artificial method. The egg is an extremely specialized structure which contains sufficient food and water to develop a fertilized cell into a chick if subjected to adequate environmental conditions. The environmental factors of major importance for artificial incubator include temperature, relative humidity, air supply and

egg turning [10-11]. These four parameters must be properly monitored during incubation.

The control of temperature is probably the most critical single factor required for the successful hatching of chicks because developing embryos are extremely sensitive to the temperature of the environment. Overheating speeds up the rate of development and causes abnormal embryo in the early hatches and consequently lowers the percentage hatchability. The relative humidity of air in an incubator for the first 18 days for chicks should be approximately 60% and during the last 3 days, it should be increased to about 70%. High moisture in the incubator prevents normal evaporation and results in low hatchability. Low moisture causes chicks to stick to the shell. Turning eggs during incubation also improves hatchability. It prevents the germ from migrating through the albumen and adhering to the shell. Eggs should be turned 3 - 5 times daily from the 2nd to the 18th day of incubation [10].

Artificial incubation is favoured in order to increase the production of chicks and protein intake, particularly in the developing countries. The electrical incubators are the best where the supply of electricity is readily available and cheap. But the supply of electricity is erratic, unreliable and high percentage of the population in the developing world is not on the electricity grid [12]. Alternative, cheap and readily available source of heat should be provided for small scale farmers who are involved in the production of chicks. Therefore, this paper presents the report of the design and construction of a solar poultry egg incubator using materials that are readily available in the local market with the aim to increase the rate of chicks' production among small scale farmers in the developing countries. The performance of the incubator was also evaluated.

2. Materials and Methods

2.1 Basic Theory

The design analysis of solar collector in this work is based on the following assumptions:

- (i) Collector performance is based on steady state conditions.
- (ii) The temperature drop between the top and bottom of the absorber plate and glazing is negligible.

- (iii) Heat flow is one dimensional through the cover as well as through the back insulation.
- (iv) Thermophysical properties of the materials are independent of temperature.
- (v) Heat losses from the front and back of the absorber are to the same ambient temperature.

2.1.1 Solar incidence radiation on collector surface

The solar declination (d) is the angular distance of the sun's rays north or south of the equator, north declination being designated as positive. The declination of the sun for any day of the year can be calculated using Eq. (1) [13]:

$$d = 23.47 \sin \left[\frac{360}{365} (284 + N) \right] \quad (1)$$

where angle is in degrees and N is the day of the year, numbering from January 1.

The intensity of direct solar radiation on a plane normal to the sun (I) is calculated using Eq. (2) [14]:

$$I = Ge^{-B/\sin a} \quad (2)$$

where, G = apparent solar radiation at air mass zero (Wm^{-2})

B = atmospheric extinction coefficient

a = solar altitude angle (degrees)

The solar altitude angle (a) is the angle between the sun's rays and the horizontal surface expressed as:

$$\sin a = \sin L \sin \delta + \cos L \cos \delta \cos(h) \quad (3)$$

where L is the latitude of a place on the surface of the earth and h is the hour angle and is expressed as:

$$h = \frac{360}{24} \times T = 15T \quad (4)$$

where T is the sun time before or after noon.

The direct radiation incident on a horizontal surface (I_h) is:

$$I_h = I \sin a \quad (5)$$

The diffuse radiation (I_d) is expressed by the following relation [13]:

$$I_d = C I F_{ss} \quad (6)$$

where, C = diffuse radiation factor

F_{ss} = angle factor between the surface and the sky

The total solar radiation on a horizontal surface (I_t) is the sum of the direct radiation incident on a horizontal surface (I_h) and the diffuse radiation (I_d) or

$$I_t = I_h + I_d \quad (7)$$

The solar radiation at normal incidence on the plane of the collector surface tilted at an angle ' δ ' to the horizontal (I_δ) is:

$$I_\delta = I_t \sin a \cos \delta \pm I_t \cos a \cos n \sin \delta \quad (8)$$

where n is solar wall azimuth in degrees. The positive sign is used when the tilted surface faces the sun and negative sign is used when the collector is tilted away from the sun.

2.1.2 Energy gained by the solar collector

The energy gained by the solar collector can be expressed by the following relation [14]:

$$Q_u = \alpha \tau I_t A_c - U_L A_c (T_c - T_a) \quad (9)$$

Where, A_c = area of transparent cover (m^2)

I_δ = total incident radiation on the collector surface ($W.m^{-2}$)

U_L = overall heat loss for the collector ($W.m^{-2}.K^{-1}$)

α = solar absorptance

τ = transmittance

T_c = collector temperature (K)

T_a = ambient air temperature (K)

The energy per unit area of the solar collector is

$$\frac{Q_u}{A_c} = \alpha \tau I_t - U_L (T_c - T_a) \quad (10)$$

If the heated air leaving the solar collector is at collector temperature, the heat gained by the air Q_g is:

$$Q_g = \dot{m}_a C_{pa} (T_c - T_a) \quad (11)$$

Where,

\dot{m}_a = mass of air leaving the collector per unit time ($kg.s^{-1}$)

C_{pa} = specific heat capacity of air ($kJ.kg^{-1}.K^{-1}$)

The collector heat removal factor, F_R , is the quantity that relates the actual useful energy gained of a collector, Eq. (9), to the useful gained by the air, Eq. (11). Therefore,

$$F_R = \frac{\dot{m}_a C_{pa} (T_c - T_a)}{A_c [\alpha \tau I_t - U_L (T_c - T_a)]} \quad (12)$$

$$\text{or } Q_g = A_c F_R [\alpha \tau I_t - U_L (T_c - T_a)] \quad (13)$$

$$\text{therefore, } \frac{Q_g}{A_c} = F_R [\alpha \tau I_t - U_L (T_c - T_a)]$$

The thermal efficiency of the collector is defined as the ratio of useful energy gain by the air to solar radiation incident on the absorber of solar collector [15]:

$$\eta_c = \frac{Q_g}{A_c I_t}$$

$$\text{or } \eta_c = F_R \left[\alpha \tau - U_L \left(\frac{T_c - T_a}{I_t} \right) \right] \quad (14)$$

2.1.3 Total heat requirement

The total heat requirement of the incubator (Q_T) is the summation of the heat energy required to raise the temperature of air (Q_a) and egg (Q_e) from $30^{\circ}C$ to $38.5^{\circ}C$; the heat loss through the wall of the structure (Q_s) and the heat loss by ventilation (Q_v) [11, 16]. Hence,

$$Q_T = Q_a + Q_e + Q_s + Q_v \quad (15)$$

The following relationships were used to determine the heat requirements:

$$Q_e = m_e C_e \Delta T \quad (16)$$

$$Q_a = m_a C_a \Delta T \quad (17)$$

$$Q_s = \frac{A_s \Delta T}{\frac{L_{wi} + L_{wo}}{k_w} + \frac{L_{ins}}{k_{ins}}} \quad (18)$$

$$Q_v = \rho_a V \Delta T \quad (19)$$

Where,

m_e = mass of eggs (kg)

m_a = mass of air (kg)

C_e = specific heat capacity of egg ($\text{kJ} \cdot \text{kg}^{-1} \cdot \text{K}^{-1}$)

C_a = specific heat capacity of air ($\text{kJ} \cdot \text{kg}^{-1} \cdot \text{K}^{-1}$)

ΔT = temperature difference (K)

A_s = surface area of the incubator walls (m^2)

L_{wi} = thickness of the incubator inner walls (m)

L_{wo} = thickness of the incubator outside walls (m)

L_{ins} = insulation thickness (m)

k_w = thermal conductivity of incubator walls ($\text{W} \cdot \text{m}^{-1} \cdot \text{K}^{-1}$)

k_{ins} = thermal conductivity of insulating materials ($\text{W} \cdot \text{m}^{-1} \cdot \text{K}^{-1}$)

ρ_a = density of air ($\text{kg} \cdot \text{m}^{-3}$)

V = ventilation rate ($\text{m}^3 \cdot \text{s}^{-1}$)

2.2 Description of the Solar Poultry Egg Incubator

The solar poultry egg incubator is shown in Fig. 1. The equipment consists of a solar

collector with built-in thermal storage unit, air ducts, incubating unit and chimney.

2.2.1 Solar collector (Air heater)

The heat absorber (inner box) of solar collector was constructed using 2 mm thick aluminium plate, painted black, is mounted in an outer box built from well-seasoned woods. The space between the inner box and outer box is filled with foam material of about 40 mm thick and thermal conductivity of $0.043 \text{ Wm}^{-1}\text{K}^{-1}$. The inner box has two compartments; one is the air flow channel (upper compartment) in between the absorber plate and transparent top cover, and the other is the thermal storage unit (lower compartment) in between the absorber plate and the back plate (Fig. 2). The overall length, width and height of the solar collector are 1200 mm, 720 mm and 330 mm respectively. The collector top glazing is a single layer transparent glass sheet of 4 mm in thickness. It has a surface area of 700 mm by 1200 mm and transmittance of above 0.7 for wave lengths in the range 0.2 – 2.0 μm and opaque to wave lengths greater than 4.5 μm . The effective area of the collector glazing is 0.66 m^2 .

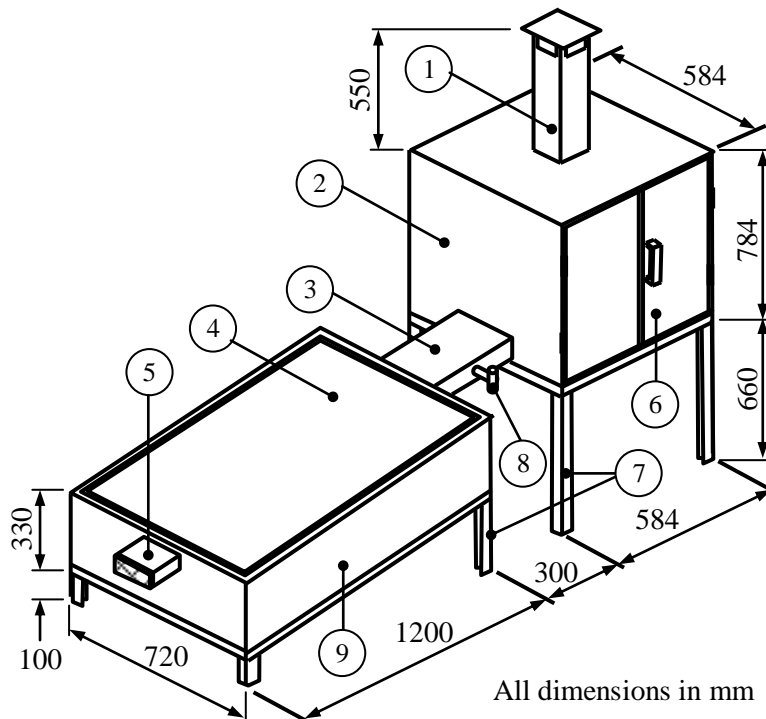

1. Chimney, 2. Incubating cabinet, 3. Air outlet duct, 4. Transparent glass cover, 5. Air inlet duct, 6. Cabinet door, 7. Stands, 8. Air flow regulator and 9. Solar collector.

Fig. 1: Solar poultry egg incubator.

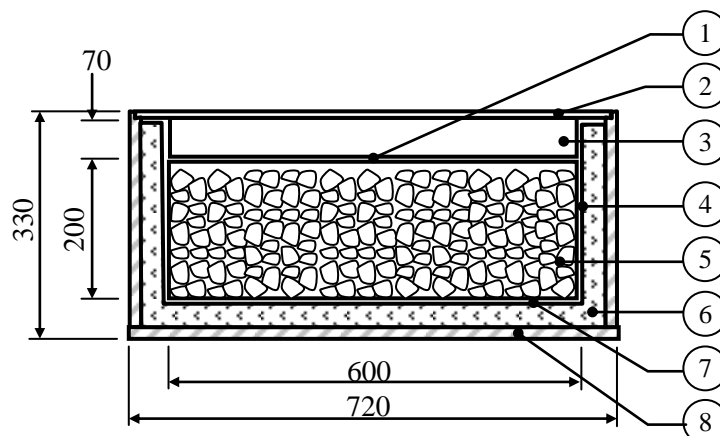

All dimensions in mm

1. Heat absorber plate, 2. Transparent glass, 3. Air flow channel, 4. Inner box, 5. Rock pebbles, 6. Thermal insulation, 7. Back plate, 8. Outer box.

Fig. 2: Cross sectional view of the solar collector.

2.2.2 Thermal storage unit

The thermal storage unit is a compartment that is located directly below the heat absorber plate (Fig. 2). It contains rock pebbles of 29 mm average diameter. The heat absorbed by the absorber plate is partially transmitted to the air flowing through the collector in the upper compartment and partially transmitted to the heat absorbing pebbles that are loosely packed inside the lower compartment (storage unit). Since the absorber plate is the source of heat to the rock pebbles, it is always at higher temperature than the pebbles during the sunshine hours. The rock pebbles are being charged at this period. During off-sunshine hours when absorber plate is collecting little or no energy, the energy stored by the rock pebbles is released and transmitted through absorber plate to the air flowing through the collector [17]. The length, width and height of the storage unit are 1100 mm, 600 mm and 200 mm respectively.

2.2.3 The orientation of the solar collector

The solar collector is always tilted and oriented in such a way that it receives maximum solar radiation during the desired season of used. The best stationary orientation is due south in the northern hemisphere and due north in southern hemisphere. Therefore, solar collector (air heater) in this work is oriented facing south and tilted at 17.5° to the horizontal. This is approximately 10° more than the local geographical latitude (Ado-Ekiti a location in Nigeria, 7.5° N), which is the best recommended

orientation for stationary absorber [18]. This inclination is also to allow easy run off of water and to enhance air circulation.

2.2.4 Air ducts

Lower end of the solar collector has an air inlet duct of 70 mm x 140 mm in cross-section, which is covered by a wire net to prevent entrance of rodents and insects. The upper end of the solar collector also has a well-lagged air outlet duct of 70 mm x 140 mm in cross-section, which serves as hot air passage from the solar collector to the incubating chamber. Both ducts are located at the upper compartment of the solar collector. Air flow regulator or damper is incorporated into the air outlet duct for the regulation of heat flow from the solar collector to the incubating chamber.

2.2.5 Incubating unit

Incubating cabinet is made up of inner and outer boxes constructed from 2 mm thick galvanized sheet metal. The external length, width and height of the outer box are 584 mm, 584 mm and 784 mm respectively, while the interior dimensions of the inner box are 500 mm, 500 mm and 700 mm in length, width and height respectively. The space between the inner box and outer box is filled with foam material of about 40 mm thick and thermal conductivity of $0.043 \text{ Wm}^{-1}\text{K}^{-1}$ to reduce heat losses. The inside of the cabinet was painted silver-white to minimize heat losses through absorption and transmission through the walls to the atmosphere. The door of the cabinet was

made from similar materials. The interior part (incubating chamber) is equipped with egg trays and holders with a turning mechanism and evaporative moisture pan to control relative humidity.

2.2.6 The chimney

It is located to the top centre of the incubating unit. It has a square cross-section area of 0.01 m² and height of 550 mm. It was constructed from 2 mm thick galvanized iron sheets.

2.2.7 Air circulation

The air circulation through the incubator is by natural convection. The cold (fresh) air that enters through the collector inlet duct is heated by the solar radiation that falls on the collector, which brings a temperature difference between the air at lower and upper ends of the collector. The temperature difference causes a density variation giving rise to buoyancy forces which in turn causes the heated air to flow through the incubating chamber and pass through the chimney without any pump. This type of fluid flow due to density gradient is usually termed the natural or thermosyphonic flow.

3. Performance Testing

The solar incubator was constructed and assembled as shown in Fig. 1. The wet bulb and dry bulb thermometers were placed inside the incubating chamber with their stems passing to outside through the holes provided on the right side wall of the cabinet where the conditions inside the cabinet could be monitored. Tests were carried out on the incubator and the values of the dry and wet bulb temperatures were used to compute the relative humidity from the psychrometric chart. The collector outlet temperature was also monitored. The incident solar radiation intensity was measured at interval of one hour between the hours of 08.00 and 18.00 local time using a portable Kipp's Solarimeter. The thermal efficiency of the solar collector (η_c) was evaluated using Eq. (14).

The incubator was first tested for 24 hours without loading the eggs in order to regulate the conditions and obtain appropriate temperatures and humidity inside the chamber. The incubator was thereafter loaded to full capacity with 100 eggs of improved fowl. Turning of the eggs is carried out at interval of six hours (four times a

day) starting from the 2nd day through to the 18th day of incubation. A Candler was used to determine the percentage fertility and hatchability of the eggs on the 8th day and 18th day of incubation respectively. The fertility and hatchability percentages were determined using Eqs. (20) and (21) [10]:

$$\% \text{ Fertility} = \frac{\text{Number of fertile eggs}}{\text{Number of eggs loaded}} \times 100\% \quad (20)$$

$$\% \text{ Hatchability} = \frac{\text{Number of eggs hatched}}{\text{Number of fertile eggs}} \times 100\% \quad (21)$$

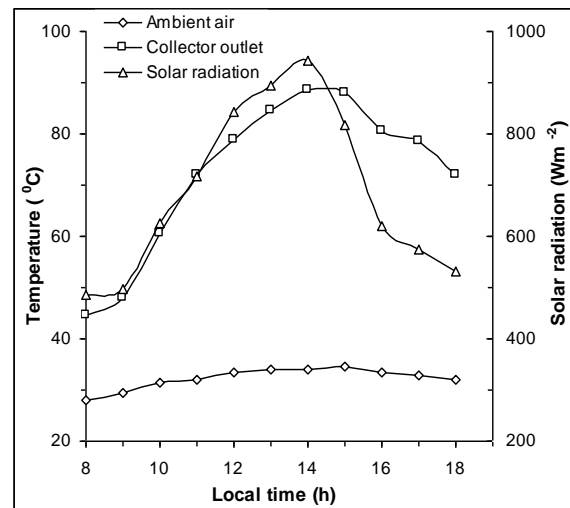

Fig. 3: Diurnal variation of temperatures and solar radiation for a typical day of highest solar radiation.

4. Results and Discussion

The diurnal variations of solar radiation intensity, ambient temperature and collector outlet temperature for typical days of highest and lowest solar radiations during a period of 21 days of incubation are shown in Figs. 3 and 4 respectively. The average collector outlet temperature and ambient air temperature obtained for the day of highest solar radiation were 72.4°C and 32.3°C during daylight respectively, while the values obtained for the day of lowest solar radiation were 51.8°C and 29.9°C during daylight respectively. During the test, a maximum collector thermal efficiency of 68.7% was obtained. The high temperature obtained in the solar collector helps maintain the design temperature of 38.5°C in the incubating chamber with slight fluctuations between +1.0 and -1.5°C throughout the incubating period. The control of temperature in the incubating

chamber was achieved through the air flow regulator incorporated in to the collector outlet duct, which regulated the heat flow from the solar collector to the incubating chamber.

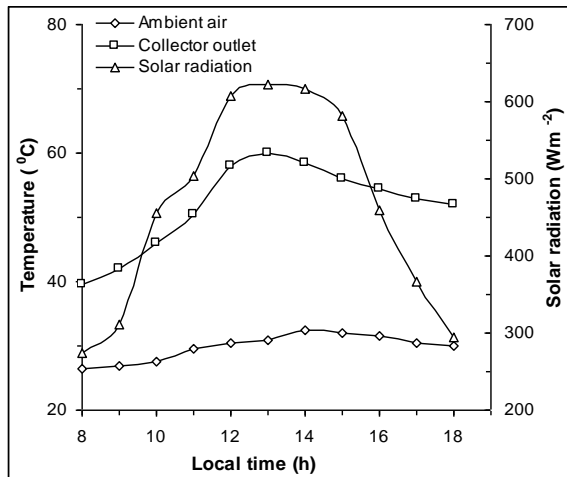

Fig. 4: Diurnal variation of temperatures and solar radiation for a typical day of lowest solar radiation.

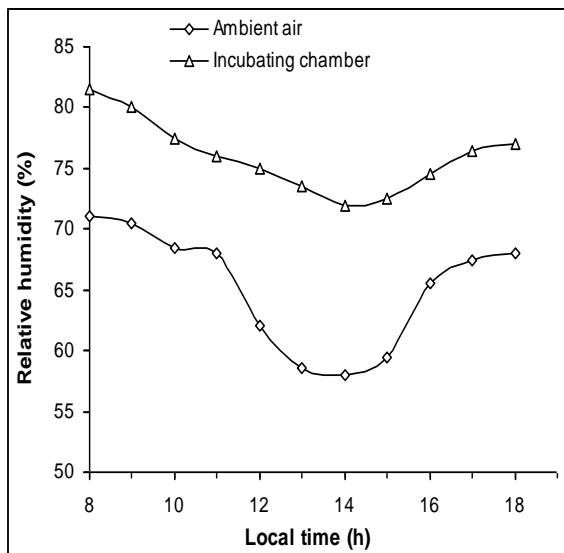

Fig. 5: A typical day diurnal variation of relative humidity of the ambient air and incubating chamber

Figure 5 shows a typical day diurnal variation of relative humidity of the ambient air and the incubating chamber. A relative humidity range of 58.0% to 71.5% was maintained in the incubating chamber throughout the incubating period. The temperature and relative humidity obtained in the incubator were within the limit of recommended environmental conditions for incubation [10, 16]. The results obtained during the test shows that out of 100 eggs set in the incubator 15 eggs were infertile (Table 1). The percentage fertility of egg was 85.0%. Also out of 85 fertilized eggs, 67 eggs were hatched (Table 2), which resulted to percentage hatchability of 78.8%.

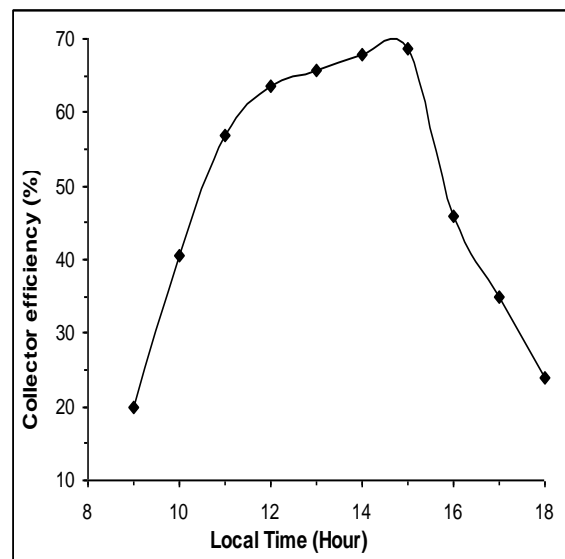

Fig. 6: Variation of collector efficiency with time

Figure 6 shows the graph of collector efficiency against local time. As shown in this figure the collector efficiency increases steadily with time between 8.00 hour and 11.00 hour and attained peak values between the hours of 12.00 to 15.00, and decreases steadily with time as the sun goes down in the late afternoon. This shows that the collector performance was optimum in the afternoon from 12.00 hour to 15.00 hour. The maximum collector efficiency obtained was 68.7%.

Table 1: Candling test on the 8th day of incubation

Group	No of eggs	Development	Observation	Remark
i.	7	Not visible	Clear	Infertile
ii.	8	Not visible	Large air space	Infertile
iii.	46	Visible at one end	Lines running across	Fertile
iv.	39	Visible at the centre	Visible patches of red stains	Fertile

Table 2: Candling test on the 18th day of incubation

Group	No of eggs	Development	Observation	Remark
i.	7	Not visible	Clear	No development
ii.	8	Not visible	Clear	No development
iii.	34	Dark appearance	Clear air space	Development in progress
	11	The whole egg is dark	No air space	Development has ceased
iv.	27	Dark appearance	Clear air space	Development in progress
	5	Dark appearance	Beak is Visible	Development near completion
	7	The whole egg is dark	Visible patches of red stains	Development has ceased

5. Conclusion

Simple and relatively cheap artificial incubators that are independent of conventional energies are favoured for the increase in production of chicks and protein intake in developing countries. Therefore, in this study, a solar poultry egg incubator was designed and fabricated using locally sourced materials to make it relatively affordable to the average poor farmer dwelling in the rural area. The incubator consisting of a solar collector with in-built thermal storage and incubating chamber of 100 eggs capacity was tested in Ado-Ekiti, Nigeria on latitude 7.5°N to evaluate its performance. The results obtained showed high thermal performance of the system. During the incubating period, average collector outlet temperatures of 72.4°C and 51.8°C were obtained on the highest and the lowest solar radiation days respectively. The incubating chamber was maintained within a dry bulb temperature range of 37.0°C to 39.5°C, and the chamber was also maintained within a relative humidity range 58.0% to 71.5% throughout the incubating period. The system solar collector thermal efficiency, percentage fertility of egg, and percentage hatchability were found to be 68.7%, 85.0% and 78.8% respectively.

6. Acknowledgement

The author wishes to acknowledge the assistance of Mr. A. Olajire, Mr. K. A. Owolabi and Mr. A. I. Adejuyigbe, former students of Mechanical Engineering Department, Federal Polytechnic Ado-Ekiti, Nigeria in carrying out this work. Also acknowledged is the supervisory role played by Late Engr. (Rev.) M. D. Ukegbu the former Dean, School of Engineering, Federal Polytechnic Ado-Ekiti, Nigeria.

References

- [1] Akinola, O. A., Akinyemi, A. A. and Bolaji, B. O., Evaluation of Traditional and Solar Fish Drying Systems Towards Enhancing Fish Storage and Preservation, *Journal of Fisheries International*, Vol. 1, No. 2 – 4, pp. 44 – 49, 2006.
- [2] Eltawil, M. A. and Samuel, D. V. K., Vapour Compression Cooling System Powered by Solar PV array for Potato Storage, *Agricultural Engineering International: The CIGR Ejournal*, Vol. 9, pp. 1 – 23, 2007.
- [3] CSC, *Solar Dryers: Their Role in Post-Harvest Processing*, 2nd Edition,

- Commonwealth Science Council, Marlborough, London, 1987.
- [4] Itodo, I. N., Obeta, S. E. and Satimehin, A. A., Evaluation of a Solar Crop Dryer for Rural Applications in Nigeria, Botswana Journal of Technology, Vol. 11, No. 2, pp. 58 – 62, 2002.
- [5] Thakur, N. S. Saini, J. S. and Solanki, S. C., Heat Transfer and Friction Factor Correlations for Packed Bed Solar Air Heater for a Low Porosity System, Solar Energy, Vol. 74, pp. 319 – 329, 2003.
- [6] Berinyuy, J. E., A Solar Tunnel Dryer for Natural Convection Drying of Vegetables and other Commodities in Cameroon, AMA, Vol. 35, No. 2, pp. 31 – 35, 2004.
- [7] Nasir, A., Design, Construction and Experimental Study of the Thermal Performance of a Parabolic Cylindrical Trough Solar Air Heater, AU Journal of Technology, Vol. 8, No. 1, pp. 21 – 26, 2004.
- [8] Bolaji, B. O., Performance Evaluation of a Box-Type Absorber Solar Air Collector for Crop Drying, Journal of Food Technology, Vol. 3, No. 4, pp. 595 – 600, 2005.
- [9] Waewsak, J., Chindaruksa, S. and Punlek, C., A Mathematical Modeling Study of Hot air Drying for Some Agricultural Products, Thammasat International Journal of Science and Technology, Thailand, Vol. 11, No. 1, pp. 14 – 20, 2006.
- [10] Adewumi, B. A. and Oduniyi, A. I., Design, Fabrication and Testing of a Charcoal Fueled Incubator, Journal of Applied Sciences, Vol. 2, No. 1, pp. 159 – 175, 1999.
- [11] Okonkwo, W., Solar Energy in Poultry Production, In: Chineke, T. C., Achunine, R. N. and Nwofor, O. K. (Eds), The Use of Solar Energy Options for Cooking, for Processing and House Lighting, Unique Books, Nigeria, pp. 54 – 67, 2002.
- [12] UNDP, Energy for Sustainable Development, <http://www.undp.org/seed/eap/activities/wea>, 2002.
- [13] Bolaji, B. O., Estimation of Solar Irradiance on Shaded Surface, Journal of the Ghana Institution of Engineers, Vol. 3, No. 2, pp. 81 – 84, 2005.
- [14] Duffie, J. A. and Beckman, W. A., Solar Engineering of Thermal Processes, 2nd Edition, John Wiley and Sons New York, 1991.
- [15] Kurtbas, I. and Turgut, E., Experimental Investigation of Solar Air Heater with Free and Fixed Fins: Efficiency and Exergy Loss, International Journal of Science and Technology, Vol. 1, No. 1, pp. 75 – 82, 2006.
- [16] Irtwange, S. V, Passive Solar Poultry Egg Incubator: Design Analysis, Journal of Applied Science and Technology, Vol. 3, No. 1, pp. 44 – 54, 2003.
- [17] Ahmad, A., Saini, J.S. and Varma, H.K., Thermohydraulic Performance of Packed-Bed Solar Air Heaters, Energy Conversion and Management, Vol. 37, No. 2, pp. 205 – 214, 1996.
- [18] Adegoke, C. O. and Bolaji, B. O., Performance Evaluation of Solar-Operated Thermosyphon Hot Water System, International Journal of Engineering and Engineering Technology, Vol. 2, 1, pp. 35-40, 2000.