

# DESIGN AND CONSTRUCTION OF A GSM-BASED HOME AUTOMATION SYSTEM

ABEREOLA, O.

NOVEMBER 2017

# DESIGN AND CONSTRUCTION OF A GSM BASED HOME AUTOMATION SYSTEM

By

**ABEREOLA, O.**

(MEE/12/0850)

A Project report submitted to the Mechatronics Engineering Department, Federal University Oye-Ekiti, Ekiti State in partial fulfilment of the requirement for the award of B.Eng. (Hons) in Mechatronics Engineering

Department of Mechatronics Engineering

Faculty of Engineering

2017

Intentionally left blank

# APPROVAL

THIS PROJECT REPORT HAS BEEN APPROVED FOR ACCEPTANCE BY THE MECHATRONICS ENGINEERING DEPARTMENT, FEDERAL UNIVERSITY OYE-EKITI, EKITI AND MEETS THE REGULATIONS GOVERNING THE AWARD OF BACHELOR OF ENGINEERING OF FUOYE.

BY

SUPERVISOR

NAME \_\_\_\_\_

SIGNATURE: \_\_\_\_\_

DATE: \_\_\_\_\_

HEAD OF DEPARTMENT

NAME: \_\_\_\_\_

SIGNATURE: \_\_\_\_\_

DATE: \_\_\_\_\_

EXTERNAL EXAMINER

NAME \_\_\_\_\_

SIGNATURE \_\_\_\_\_

DATE \_\_\_\_\_

## **DEDICATION**

This project work is dedicated to God Almighty, the creator of the whole universe for His mercies that are never giving up on me. Also, to my parents, Mr. and Mrs. Abereola, Dr. S.N Abereola, the university chapel [chapel of transformation], well-wishers, our families, lecturers, staffs, fellow mechatronics students and logistic course mates whose love, moral support, valid and quick information helped me make it through the hard times; thanks for believing in me.

## ACKNOWLEDGMENT

Sincerely, the satisfaction I derived from completing this project work will not be well expressed without recognizing those who God stationed at every facets to make it possible; no doubt that without the roles played by these people, the project may not see the light of the day today-and it is all because of Jesus' grace upon me throughout the periods of my undergraduate studies. All thanks to God.

I am indebted to my supervisor Engr. Dr. A.A Adekunle who also heads our department for his availability, provision of required materials, encouragement, moral supports and constant brainstorming that was at the end a greater help towards my ability to finally come up with a mechatronics project in my final phase as an undergraduate, I am grateful sir.

My appreciation goes to Prof. Christian Bolu, our former dean and our first Don in this department who aroused my interest in mechatronics engineering. My profound gratitude also goes to Engr. Dr. A.V Balogun, our don in the department and Deputy H.O.D who lifted my spirit during his classes with us during sensors and actuators, signals and systems and others that mechatronics is not limited to the development of robots alone, that the automation of engineering processes at home and industries through the employment of sensors, actuators, signals and programs is purely mechatronics; am grateful sir because this knowledge was what guided my thinking that I could automate our homes, a factor that lead to the development of this project. Thanks so much sir. Same goes to Engr. A.A Aribisala who was always available to help me with materials and advice towards the fulfilment of this project. My heart goes out to Engr. Joshua Owoyemi who had been there for me all the way from Japan in achieving this project. To Engr. Martins Oluwaseun, am grateful. To all our academic and non-academic

staffs in the department of mechatronics engineering, am grateful for each of your unquantifiable roles played in making me a certified mechatronics Engineer.

My profound gratitude goes to my Parents *Mrs. Janet Abereola, Dr. S.N Abereola, siblings and well-wishers*, God bless you all.

## **ABSTRACT**

With advancement of technology, things are becoming simpler and easier for us. Automatic systems are being preferred over manual systems. The purpose of this project is to design and construct A GSM based home automation using AVR. Using GSM networks, in this project a home power control system has been proposed that will act as an embedded system which can monitor and control appliances and other devices locally using built-in input and output peripherals. The system has a delay of 2 two minutes after the first call to initiate the next command. This project is made up of four vital units. These units are as follows: GSM module unit, peripheral interface control (PIC) unit, driver unit and a power monitoring and control unit. The GSM module is a GSM transceiver which gives the system access to the GSM service provider. The peripheral interface control (PIC) is programmed to carry out the OFF/ RESET operation according to the GSM commands while the driver and control unit consist of capacitors, resistors, diodes, regulators and electromagnetic relay is to effect power switching. The major component that performed the power control of 220v main supply and the automatic voltage regulation (AVR) is the automated electromagnetic relay. The project was realized and a light bulb was literarily used for the demonstration; it was automated using the system developed.



# TABLE OF CONTENTS

APPROVAL.....	i
DEDICATION .....	ii
ACKNOWLEDGMENT.....	iii
ABSTRACT.....	v
TABLE OF CONTENTS.....	vi
LIST OF TABLES .....	x
LIST OF FIGURES .....	xi
LIST OF ABBREVIATIONS.....	xiii
CHAPTER ONE .....	1
1.1 INTRODUCTION .....	1
1.1.1 DTMF Decoder .....	2
1.1.2 Basic Concepts of DTMF .....	2
1.2 BACKGROUND OF THE STUDY .....	3
1.3 STATEMENT OF PROBLEM.....	5
1.4 JUSTIFICATION OF THE PROJECT.....	5
1.5 AUTOMATION.....	6
1.6 PROJECT AIM.....	8
1.6.1 Project Objective.....	8
1.6.2 Purpose of the Project .....	8
1.7 METHODOLOGY.....	8

1.8 ORGANIZATION OF THE WORK .....	9
1.9 DEFINITION OF TERMS.....	9
CHAPTER TWO .....	11
2.1 LITERATURE REVIEW .....	11
2.1.2 Background Review .....	12
2.1.2 Review of Related Works .....	13
2.2 HOME AUTOMATION SYSTEM.....	13
2.3 BRIEF HISTORY OF TONE RECOGNITION DEVICE .....	15
2.4 HISTORY OF HOME AUTOMATION .....	15
2.4.1 The Mechanical Evolution .....	16
2.8 The Electrical Evolution .....	16
2.9 The Information Revolution.....	17
2.5 SMART HOME TODAY .....	18
2.5.1 Aspects of Automatic Speech Recognition (asr) Device .....	19
2.6 TECHNICAL DETAILS OF GSM.....	20
2.13 Subscriber Identity Modula (sim) as a GSM feature .....	21
CHAPTER THREE.....	22
3.1 MATERIALS AND METHODS.....	22
3.2 DESCRIPTION OF COMPONENTS .....	22
3.21 Component Description .....	23
DESCRIPTION.....	26
3.3 PHYSICAL DESCRIPTION OF TRANSISTORS .....	35

3.3.1 Principle of Operation .....	35
3.3.2 Hardware Subsystems .....	35
3.4 SYSTEM ANALYSIS AND DESIGN .....	36
3.5 CIRCUIT DESCRIPTION .....	37
3.6 CODE/PROGRAMM DESCRIPTION .....	38
3.7 TRANSFORMER .....	41
3.8 REGULATION UNIT/DESIGN CALCULATION .....	43
3.10 The Power Supply .....	44
3.9 THE MICROCONTROLLER .....	45
3.10 RELAYS AND TRANSISTORS COMPARED .....	49
CHAPTER FOUR.....	51
4.1 SYSTEM IMPLEMENTATION AND PROJECT COSTING .....	51
4.2 CONSTRUCTION .....	51
4.2.1 Constructional Method.....	52
4.3 POWER SUPPLY UNIT [PSU] .....	52
4.4 MOUNTING OF THE COMPONENTS .....	54
4.5 INTERCONNECTION OF COMPONENTS.....	54
4.6 BILL OF ENGINEERING MATERIALS AND EVALUATION .....	56
CHAPTER FIVE: CONCLUSION, RECOMMENDATIONS AND CONSTRAINTS.....	59
5.1 CONCLUSION .....	59
5.2 RECOMMENDATIONS .....	59
5.3 CONTRIBUTION TO KNOWLEDGE.....	60

5.4	MAJOR CONSTRAINTS.....	60
5.4.1	Constraints Considerations .....	60
5.5	TECHNOLOGY CONSIDERATIONS .....	61
	REFERENCES.....	62
	APPENDICES .....	64
	Appendix 1.1: Bill of Engineering Materials and Evaluation [BEME].....	64
	Appendix 1.2: Programming/Code Used .....	67
	CURRICULUM VITAE OF THE DESIGNER AND RESEARCHER.....	73

## **LIST OF TABLES**

Table 1.1: Dual Tone Multi Frequency [DTMF] .....	20
Table 3.1: Table of components .....	72
Table 4.1: Bill of Engineering Materials and Evaluation .....	80

## LIST OF FIGURES

Fig. 1: What a smart home could be like.....	19
Fig. 2: Pin diagram .....	41
Fig 3: Transformer .....	43
Fig 4: Voltage regulator .....	44
Fig 5: Bridge Rectifier .....	44
Fig. 6: Phone (Nokia 1280) .....	45
Fig. 7: CD7414 .....	46
Fig. 8: 74154 .....	46
Fig. 9: LED .....	47
Fig. 10: Diode .....	48
Fig. 11: Capacitor .....	49
Fig. 12: Resistor .....	49
Fig. 13: Transistor .....	50
Fig. 14: GSM module .....	51
Fig. 15: CBD.....	53
Fig. 16: Circuit Diagram of the project .....	55

Fig. 17: Transformer .....	64
Fig. 18: Power supply/Receiver .....	67
Fig. 19: Micro controller .....	67
Fig. 20: Flowchart of the system .....	68
Fig. 21: Picture of four types of Diodes.....	69
Fig. 22: Picture of Electrolytic Capacitor .....	70
Fig. 23: Resistor .....	70
Fig. 24: Design Set-ups .....	72
Fig. 25: Operational block diagram .....	73
Fig. 26: Micro-chip .....	74
Fig. 27: Vero board .....	75
Fig. 28: Complete construction box of the project circuit .....	77

## **LIST OF ABBREVIATIONS**

DTMF: Dual Tone Multi Frequency.

LED: Light Emitting Diode.

GSM: Global system for mobile communication

SSADM: Structured System Analysis and Design Methodology.

IVR: interactive voice response

ASR: Automatic speech recognition.

Ac: Alternating current

ARPA: American research project agency

ADC: Analogue to Digital converter

CPU: Central processing unit.

RAM: Random Access Memory. This is a kind of memory that stores data temporarily.

ROM: Read Only Memory. This is a kind of memory that stores information permanently.

UART: Universal Asynchronous Receiver Transmitter

SMS: Short message service

MODEM: Modulation and Demodulation

PIC: Peripheral Interface Control



AVR: Automatic Voltage Regulation

BAS: Building Automation System

SCADA: Supervisory Control and Data Acquisition

## CHAPTER ONE

### 1.1 INTRODUCTION

Home automation is not a new concept in today's world, it is used to provide convenience for users to remotely control and monitor appliances as well as better power management. The efficient use of electricity makes the HOME automation play an important role in our daily life. Mobile phones are getting more advanced which allow people to develop applications that run on them. Currently mobile phones are gradually replacing PCs because of their ability to do almost all whatever computers can do. Remote management and control of devices is one of the areas where an application can be developed to make our life easier. Different approaches can be followed to develop remote management or control systems, some use DTMF (Dual Tone Multi Frequency) technology which involves using mobile phones tone to perform an action, while some use SMS technology to send the command for a particular action, some also use GPRS (General Packet Radio Service) technology to directly interface mobile phone and the computer. Imagine how helpful it will be to be able to switch on your air conditioning system ten minutes before you get home on a hot afternoon in January. This is what home automation is about and there is no end to its application. In fact, sophisticated home automation systems are now being developed that maintain an inventory of household items, record their usage through an RFID (Radio Frequency Identification) tag, and prepare a shopping list or automatically order replacements. Home automation has made it possible to have what is often referred to as a smart home, a home where you can switch on the security lights at night and switch them off in the morning, heat water for bathe and tea, stream to you anywhere in the world via the internet a live video of what is happening in and around your house. It makes it possible to link lighting, entertainment, security, telecommunications, heating, and air conditioning into one centrally controlled system. This allows you to make your house an active partner in managing your busy life. Nowadays, you can hardly find a house without a home automation system which can range from the remote for the television, burglar alarm and hi-tech security gates, to an automated air conditioning system that maintains the temperature at a predefined value.

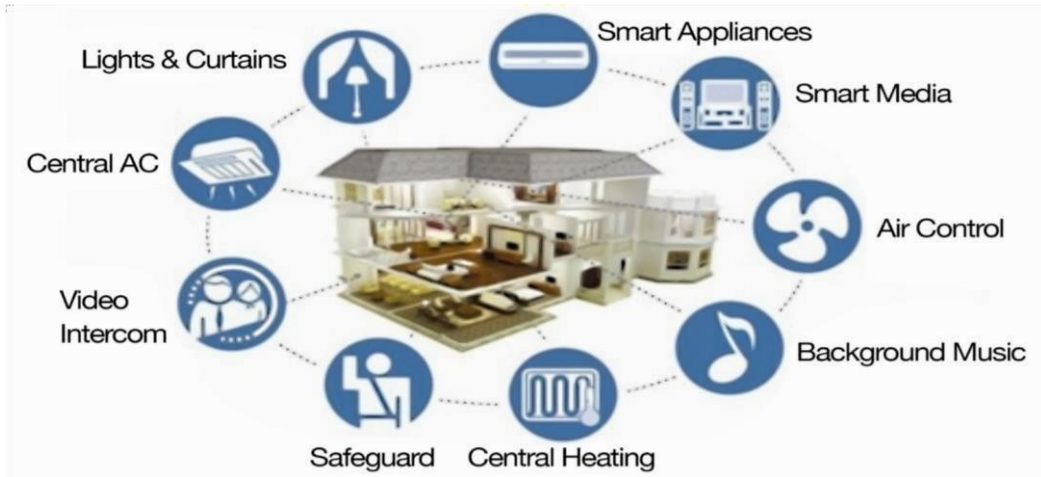

Figure 1.1: What a Smart Home Could Be Like

### 1.1.1 DTMF Decoder

In DTMF decoder circuit, This IC MT8870 was used. IC MT8870 converts the dual tones to corresponding binary outputs which are then processed by various circuits in the device.

### 1.1.2 Basic Concepts of DTMF

In our mobile phone keypad, each number (including „#“ and „\*“) is associated with unique frequency, this frequency is the sum of a high frequency and a low frequency component, i.e. mixture of two pure tone, hence Dual Tone Multi Frequency.

To be clearer, when a call channel is established, if you press a key on the keypad, you and the called party hear a distinct sound, this is the dual tone which is associated with that number pressed and is passed through the DTMF channel to the called party. Similarly, all 10 numbers (0-9), including „#“ (hash) and „\*“ (asterisk) has a unique dual tone [5] associated with it. The 2 individual pure tones which constitute the dual tone for each number is as shown below, wherein the corresponding rows give the low frequency tone and the columns, the high frequency tone[3]. \*A B C D was removed from standard keypads and is now used in military for priority call. If you press 7, your phone sends a signal having a frequency  $852\text{Hz} + 1209\text{Hz} = 2061\text{Hz}$  and the receiver receives the same. The main advantage of such a

concept is that the dual tone frequency is relatively higher than that of the average environmental noise; hence the DTMF channel only transmits the dual tone and not the relatively low noise frequencies. Also the receiving station can be automated. i.e. the receiving device can be designed (using pass filters) to receive and decode the dual tone using dtmf decoder [10] and programmed to carry out specific functions corresponding to the number pressed.

**Table 1.1: DUAL TONE MULTI FREQUENCY [DTMF] TABLE ANALYSIS**

	1209Hz	1336Hz	1477Hz	1633Hz
167Hz	1	2	3	A*
770Hz	4	5	6	B*
852Hz	7	8	9	C*
941	*	0	#	D*

**1.2 BACKGROUND OF THE STUDY**

Has technology transformed humankind into omniscience being? Years back Communication was done through difficult means like travelling to the Destination of the second party, posting letters etc. Today, people can Communicate easily through various means like e-mailing, face booking, GSM etc. The new age of technology has redefined communication most people nowadays have access to mobile phones and thus the world indeed has become a global village. At any given moment, any particular individual can be contacted with the mobile phone. But application of mobile phones cannot be restricted to sending SMS or starting conversation. New innovation and ideas can be generated from it that can further enhance

its capabilities. Technologies such as infra-red, Bluetooth etc. which has developed in recent years goes to show the very fact that improvement are in fact possible and those improvement have eased our life and the way we live. Remote management of several home and office appliances is a subject of growing interest and in recent years we have seen many systems providing such controls.

These days, apart from supporting voice calls, a mobile phone can be used to send text message as well as multimedia message (that may contain pictures, graphics, animation, etc.). Sending written text messages is very popular among mobile phone users. Instant messaging as it is known, allows an individual to share ideas, opinions and other relevant information. I have used this to design a system that allows a platform to receive calls which in fact are commands sent to control different appliances and device connected to the platform and I took the lightning system of our departmental board room as a case study. The design of this control system is based on the GSM technology that effectively allows control from a remote area to the desired location. The application of the suggested system is immense in the ever changing technological world. It allows a greater degree of freedom to an individual whether it is controlling the household appliances or office equipment. The need to be physically presenting order to control appliances of a certain location eliminated with the use of this system. The research is borne out of the need for man to control electrical devices that are remotely located to him. Anything from home devices such as alarms, heaters, air conditioner and so on, IT equipment such as routers and servers can be controlled. The desire for man to control an object that is remotely located to him has been for many ages. However, the technology that meets the perfect desire in this respect has not been obtained, though there is increasing improvement in technology that struggles to meet this need in terms of accuracy, speed, ease of operation and limitless operation point. The introduction of the global system for mobile communication (GSM) and particularly the use of handheld mobile phones brought the innovation of distance communication at remote location. Based on this, research utilizes this facility for remote control of systems and appliances, take for instance, a man on a journey inside his car suddenly remembers that he left the air conditioner (AC) or Light ON when it was supposed to be OFF. The normal condition is to

drive back and switch OFF. But with the GSM/mobile phone in the hand, one looks on how the same could be used to effect control at any point and time; and this is one of the key aims of mechatronics engineer either in automation or robotics; that we become engineers running our worlds with a remote control or an agent.

### **1.3 STATEMENT OF PROBLEM**

Technology has advanced so much in the last decade or two that it has made life more efficient and comfortable. The comfort of being able to take control of devices from one particular location has become imperative (i.e. important) as it saves a lot of time and effort. Therefore there arises a need to do so in a systematic manner which will be implemented in the proposed system. The system is an extended approach to automating a control system.

With the advancement and breakthrough in technology over the years, the lives of people have become busier than before. With the adoption of this system, we can gain control over certain things that require constant attention. The application of this system comes in handy when people who forget to do simple things such as turn ON or OFF devices at their homes or at their offices or even factories. They can now do so without their presence by the transmission of a simple call from their mobile phone. This development, I believe will ultimately save a lot of time especially when people do not have to come back for simple things such as to turn ON or OFF at their homes or at their office or even factories once they set out for their respective appointments.

### **1.4 JUSTIFICATION OF THE PROJECT**

- 1) The proposed project can be used as a reference or as a base of realizing a scheme to be implemented in other project of greater level such as device synchronization, temperature updates, weather forecasting etc.
- 2) The project itself can be modified to achieve a complete home automation system which will then create a platform for the user to interface between himself and the household.

- 3) It can be used by companies for management purpose example is switching ON/OFF the server in other to manage the bandwidth.

## **1.5 AUTOMATION**

Automation is the use of control systems and information technology to control equipment, industrial machinery and processes, reducing the need for human intervention. In the scope of industrialization, Automation is a step beyond mechanization. Mechanization provided human operators with machinery to assist them with the physical requirements of work while automation greatly reduces the need for human sensory and mental requirements as well.

Automation plays an increasingly important role in the global economy and in daily experience. Engineers strive to combine automated devices with mathematical and organizational tools to create complex systems for a rapidly expanding range of applications and human activities.

Many roles for human in industrial processes presently lie beyond the scope of automation. Human-level pattern recognition, language recognition, and language production ability are well beyond the capabilities of modern mechanical and computer systems. Tasks requiring subjective assessment or synthesis of complex sensory data, such as scents and sounds, as well as high-level tasks such as strategic planning, currently require human expertise. Automation has had a notable impact in a wide range of highly visible industries beyond manufacturing. Medical processes such as primary screening in electrocardiograph or radiography and laboratory analysis of human genes, blood plasmas, cells, and tissues are carried out at much greater speed and accuracy by automated systems. Automated teller machines have reduced the need for bank visits to obtain cash and carry out transactions. In general, automation has been responsible for the shift in the world economy from agrarian to industrial in the 19<sup>th</sup> century and from industrial to services in the 21<sup>st</sup> century Office automation Office automation refers to the varied computer machinery and software used to digitally create, collect, store, manipulate, and relay office information needed for accomplishing basic tasks and goals. Raw data storage, electronic transfer,

and the management of electronic business information comprise the basic activities of an office automation system, office automation helps in optimizing or automating existing office procedures. Building automation describes the functionality provided by the control of a building. The control system is a computerized, intelligent network of electronic devices, designed to monitor and control the mechanical and lighting systems of a building. A building automation system is an example of a distributed control system. The building automation system (BAS) core functionality keeps the building climate within a specific range, provides lighting based on an occupancy schedule, and monitors system performance and device failures and provides email and/or text notifications to building engineering staff. The BAS functionality reduces building energy and maintenance costs when compared to a non-controlled building.

Power automation is the automated control and monitoring of power plants, substations and transformers for effectiveness, efficiency and fault detection. It has made it possible to have a reliable municipal or national electricity system, which often comprises remote and hard-to-reach transformers and power sub-system units. It makes it possible to monitor different power units, relay their status and health information, and even carry out fault detection and correction without human interference. Example of power automation system is the Supervisory Control and Data Acquisition (SCADA) system. Home automation may designate an emerging practice of increased automation of household appliances and features in residential dwellings, particularly through electronic means that allow for things impracticable, overly expensive or simply not possible in recent decades. Home automation includes all that a building automation provides like climate controls, door and window controls, and in addition control of multimedia home theatres, pet feeding, plant watering and so on. But there exists a difference in that home automation emphasizes more on comforts through ergonomics and ease of operation.



## **1.6 PROJECT AIM**

The aim of this project is to design and construct a home automation system that will remotely switch on or off any household appliance connected to it with the use of a mobile phone; taking lightning as a case study.

### **1.6.1 Project Objective**

The objective of this project is

- (i) To implement a low cost, reliable and scalable home automation system
- (ii) To construct a circuit that can be used to remotely switch on or off any household appliance, using a microcontroller to achieve hardware simplicity, from any phone to toggle the switch state.

### **1.6.2 Purpose of the Project**

The project covers the aspect of just being able to switch ON/OFF any electrical appliance connected to the circuit.

The purpose is to be able to switch on/off Electrical appliances from anywhere in the world and to have access to your home/office appliances without physically present. This project is to overcome the distance limitation of Bluetooth, Infra-red etc.

## **1.7 METHODOLOGY**

Initial approach to project designing and execution is to gather enough information in order to help speed up the operation once the actual work commences. Methodology is the study of how to perform scientific research. It is the part of any analysis or research that is used to find out what type of data is maintained, what fact to find and look for, how to find them and how to record them for usage. In order to achieve these, Structured System Analysis and Design Methodology (SSADM) were used. This is because; SSADM is an internationally accepted software engineering model mainly used in most result oriented analysis.

## **1.8 ORGANIZATION OF THE WORK**

- \* The project is designed to have five chapters, which is clearly detailed.
- \* The first chapter gives an introduction to GSM control system along with the project aims and objectives, with emphasis to the scope in order to achieve the desired goal and limitations to the study.
- \* Chapter two is on literature review which contains a review of previously implemented systems.
- \* Chapter three contains the details of the entire major component that were used in the actualization of the hardware part of the project.
- \* Chapter four deals with the implementation and the testing, the chapter contains the major work of the project.

Chapter five summarizes and concludes the project work on GSM – Based Remote switching system.

Recommendations are also stated.

## **1.9 DEFINITION OF TERMS**

**DTMF:** This is short for Dual Tone Multi Frequency. It is a generic communication term for touch tone (a Registered Trademark of AT&T). The tones produced when dialing on the keypad on the phone could be used to represent the digits, and a separate tone is used for each digit. Pressing any key generate unique tone which consists of two different frequencies one each of higher and lower frequency range. The resultant tone is convolution of two frequencies

**LED:** Light Emitting Diode. The LED is a diode which glows when the current passes through it in forward bias condition.

**GSM:** Global system for mobile communication

**SSADM:** Structured System Analysis and Design Methodology. SSADM is an internationally accepted software engineering model mainly used in most result oriented analysis.

**IVR:** interactive voice response

**ASR:** Automatic speech recognition. This is the process by which a computer maps an acoustic speech signal to some form of abstract meaning of the speech.

**Ac:** Alternating current

**ARPA:** American research project agency

**ADC:** Analogue to Digital converter

**CPU:** Central processing unit. The part of a computer that fetches and executes instructions.

**RAM:** Random Access Memory. This is a kind of memory that stores data temporarily.

**ROM:** Read Only Memory. This is a kind of memory that stores information permanently.

**UART:** Universal Asynchronous Receiver Transmitter

**SMS:** Short message service

**MODEM:** Modulation and Demodulation

## CHAPTER TWO

### 2.1 LITERATURE REVIEW

For many years now, a lot of people have worked on home automation. Home automation can be described as introduction of technology within the home environment to provide convenience, comfort, security and energy saving to its occupants. Adding intelligence to home environment can provide increased quality of life for the elderly and disabled people who might otherwise require caregivers or institutional care. There has been a significant increase in home automation in recent years due to higher affordability and advancement in phones. Various works have been carried out with the use of microcontrollers to design Home Automation. Some of these works includes:

- Implementing of home automation system were considered by (Ciubotaru,etal.,) and (Delgado,et,al.,2006) who presented designs and implementations of SMS -text based control .

This work uses SMS – to control home appliances and this give the project a limitation because you will not know if the SMS gets to the phone in the project or not.

- Yun Chan Cho and Jae Wook Jeon “Remote Robot control System based on DTMF of Mobile Phone”, IEEE International Conference INDIN 2008, July 2008.

The limitation of this project is that it only uses Android phone, means if you don't have an Android phone, you will not be able to control the home appliances, and the component used for this project is quite expensive.

- Rifat Shahriyar<sup>1</sup>, Enamul Hoque<sup>2</sup>, S.M. Sohan<sup>3</sup>, Iftekhhar Naim<sup>4</sup>,

Md. Mostafa Akbar<sup>5</sup> & Masud Karim Khan<sup>6</sup> *Department of Computer Science & ,*

*Engineering Bangladesh University of Engineering & Technology, 6 Windows Mobile Division at Microsoft International journal of smart Home* Vol. 2, No. 3, July, 2008 The limitation of this project is that it uses Bluetooth, which means you can only control any Home appliance when you are close to it, or depending on the kilometre radius that the Bluetooth can cover.

➤ Afif Mghawish, Akram A. AbdelQader, Mahmoud A. Al-Jezawi, Mohammad

AbuMahfouz. Multi-Function Control System using GSM modem Based SM5100B Module. ICITST-2012 London, Technical CoSponsored by IEEE UK/RI Computer. The limitation of this project is that you must be connected to the internet before you can control any Home appliance.

The limitation of this project is that it uses remote control that means if you don't have the remote, you can't control any home appliance.

### 2.1.2 Background Review

The first machines to be operated by remote control were used mainly for military purposes. Radio-controlled motorboats, developed by the German navy, were used to ram enemy ships in World War I. Radio controlled bombs and other remote control weapons were used in World War II. Once the wars were over, United States scientists experimented to find non-military uses for the remote control. In the late 1940's automatic garage door openers were invented, and in the 1950's the first TV remote controls were used. Zenith began playing around with the idea of a TV Remote control in the early 1950's. They developed one in 1952 called "Lazy Bones," which was a long cable that was attached to the TV Set. Pushing buttons on the remote activated a motor that would rotate the tuner in the set. This type of remote wasn't popular for long considering that, at the time, there were very few channels to choose from.

In 1955, the Flashomatic was invented. A flashlight was shined toward light sensitive cells in each of the four corners of the TV. Each corner had different function. They turned the TV on and off, changed the channel, and controlled the volume. However, people often forgot which corner of the TV operated which

control. Also, if the set was in sunlight, the sun's rays would affect the operations of the TV. In 1957 a group of engineers developed the Zenith "Space Command," a wireless remote control using ultrasonic waves. The problem with the ultrasonic control was that clinking metal, such as dog tags, could affect the TV set. High frequencies sometimes also made dog bark. The ultrasonic remote was used for two decades until engineers discovered a better way to operate TV's, the infrared remote control. On the infrared control, each button has its own command, and is sent to the TV set in a series of signals. There is a digital code for each button, and in the TV there is a tiny sensor called a photo detector that identifies the infrared beam, and translates the code into a command. Manufacturers used to only make remote controls that operated one TV set. However, they've recently begun making universal remote controls that can operate any TV set. Experts predict that someday remote controls will control almost every device in the home. R.C. Goertz developed a mechanical manipulator in 1948 to aid in radioactive lab work.

Goertz gave the machine mechanically and geometrically similar "master" and "slave" parts. The master was the part of the machine the Goertz controlled, and used to send the slave commands. The slave followed the master's movements exactly. In 1954 an electric machine was made to replace Goertz's machine, which was operated by cables. Since '54 better design has been developed, but the electric manipulator remains relatively unchanged to this day.

### 2.1.2 Review of Related Works

Here, some research such as Home Automation system and its application, Tone recognition devices, Automatic Speech recognition, the technical detail of GSM will be looked into as they relate to remote control systems.

## **2.2 HOME AUTOMATION SYSTEM**

A common definition of Home Automation is of an "electronic networking technology to integrate devices and appliances so that the entire home can be monitored and controlled centrally as a single machine"(Pragnell et al., 2000). Another term that describe the same technology is "domotics", which

derives from the Latin word *domus*, meaning home, and informatics, meaning the study of the processes involved in the collection, categorization, and distribution of data. However, since this technology is still very much in flux, other terms are also used in the literature with equivalent meaning, such as: “smart home”, “smart house”, “digital home” or electronic home”.

Furthermore, the possible solutions are devices through various network technologies. Several issues affecting home automation systems such as lack of robustness, compatibility issue and acceptability among the old and disabled people are discussed. (Ciubotaru-Petrescu, et al., 2006) present a design and implementation of SMS based control for monitoring systems. The paper has three modules involving sensing unit for monitoring the complex applications. A processing unit that is, microcontroller and a communication module that uses GPRS modem or cell phone via serial port RS-232. The SMS is used for status reporting such as power failure. In their paper, (Scaradozzi et al., 2003) view home automation systems as multiple agent systems (MAS). In the paper home automation system has been proposed that includes home appliances and devices that are controlled and maintained for home management. The major task is to improve performance. In their paper, (Alkar and Buhur 2005) propose an Internet Based Wireless Home Automation System for Multifunctional Devices. This paper proposes a low cost and flexible web-based solution but this system has some limitations such as the range and power failure.

Murthy (2008) explores primary health-care management for the rural population. A solution proposes the use of the mobile web-technologies providing the PHC services to the rural population. The system involves the use of SMS and cell phone technology for information management, transactional exchange and personal communication. (Jawarkar, et al., 2008) propose remote monitoring through mobile phone involving the use of spoken commands. The spoken commands are generated and sent in the form of text SMS to the control system and then the microcontroller on the basis of SMS takes a decision of a particular task. (Potamitis, et al., 2003) suggest the use of speech to interact remotely with the home appliances to perform a particular action on behalf of the user. The approach is inclined for people with disability to

perform real- life operations at home by directing appliances through speech. Voice separation strategy is selected to take appropriate decision by speech recognition.

### **2.3 BRIEF HISTORY OF TONE RECOGNITION DEVICE**

Despite the fact that the largest stride in the development of tone recognition devices has occurred in the past two decades, this aspect of technology really began with Alexander Graham Bell's invention at about 1870. In his discovery, conversion of sound waves into electrical signals started the process of exploring scientific and mathematical basis for understanding Bell Laboratories. In the 50's developed the first effective tone recognition for numbers. At about 1970, the American Research Project Agency (ARPA) after various researches on speech understanding developed the technology further focusing particularly on the fact that the objective of automatic tone recognition is the understanding of speech not merely words. By the 80's distinct types of products are available, they offered speaker independent recognition systems such that document could be created by voice dictation. The last two decades has invariably a development of voice recognition to the point of real-time continuous speech systems with exceptional high accuracy.

### **2.4 HISTORY OF HOME AUTOMATION**

Although the term "home automation" was first used in 1980s, the concept is far from new. The early documented attempt to envisage something very similar dates back to the 1960s, with Walt Disney's Experimental Prototype Community of Tomorrow (EPCOT), presented in 1966. A smart home will not be able to accomplish much without appliances to control, nor will it be able to communicate to these devices in the absence of a control network ("home network"). Since appliances and home network are so interlinked with a smart home, the following sections provide a brief history on how these come into being.



### 2.4.1 The Mechanical Evolution

The first question that might come to mind is why we would need a Smart Home and why we would want to find different ways of doing ordinary things, such as washing clothes, cooking, or even turning a light on or off. A similar question could have been asked at the beginning of the 20th Century, at the dawn of what can be called the “mechanical revolution”. In late 1800’s, the middle class was experiencing a shortage of domestic servants which created the need to find new ways to provide help in the home (Harper, 2003). Such necessity was the initial driving force behind the inventions of the first domestic appliances, which had the purpose of making household chores easier and do more with less. In 1911, Frederick

Winslow Taylor published “The Principles of Scientific Management”, which advocated the use of efficiency to maximize results through minimal effort. This theory is today known as Taylorism and, though it was originally intended to be applied in industrial settings, this concept soon spilled over into the domestic realm due to the need at hand. Christine Frederick (1911) was one of the first to recognize that the challenges tackled by Taylorism were also directly applicable to domestic issues and captured these in her book “Household engineering:

Scientific Management in the Home”, published in 1915. In her book, Frederick predicts that mechanical appliances would be the ones which were to take up the work originally performed by servants “where every possible purely manual task is done by arms of steel and knuckles of copper”. She also puts forward the idea of a Smart Home where she foretells that “such machinery will be far more unified than at present with various pieces related to one another”, as reported by D. Heckman (2008).

### 2.8 The Electrical Evolution

In spite of the first inventions, most of this new domestic technology would have still been easily recognized by people who had lived in the previous Century. However, electricity, the driving force behind the electrical revolution, would soon change this familiar landscape beyond recognition. Electrical

energy first arrived in the homes around 1920s and, although initially used for lightning purposes only, by 1940s mains electricity was readily available to around 65 per cent of the total of houses in the UK. (Harper, 2003). Soon after it reached a critical mass, producers of electrical appliances inundated the market with all sorts of items. Although some of them were nice-to-have-devices, such as electric popcorns poppers, egg cookers and waffle irons, others were really life changing for the household: refrigerators, washing machines, electric cookers, vacuum cleaners, just to mention the most important. Regardless of their importance, all these electrical appliances were still made with the original need in mind, which was often reminded to people as producers marketed these products with time-saving slogans such as “no longer tied down by housework” or “automatically gives you time to do those things you want to do” (Heckman, 2008). It is interesting to note how some later devices could be hardly classified as time savers and how, in spite of this, they were still quite readily adopted. By early 1980s, around 65 per cent of

UK homes had a colour television set and half of them a video recorder (Harper, 2003). More interesting still, the adoption curve was different from one to another, sometimes regardless of the comfort that they could bring.

## 2.9 The Information Revolution

Disney’s original vision for EPCOT was to create both a laboratory for new technology and a home for its inhabitants with the promise of offering an “integrated living environment” (Heckman, 2008). Due to his untimely death, just a few months after the official presentation of the project, EPCOT was never implemented, at least not in its original idea. The concept behind the original vision was however to live on. In the 1960s, a number of hardware and software innovations made possible for home owners to have access to the first computer like appliances in their homes. Perhaps the first attempt to create a “home automation” system occurred in 1966 when Westinghouse proposed the experimental – and quite bulky – Electronic Computing Home Operator (ECHO)

IV. Although the original system was supposed to automate the family finances, it was soon extended to include recipes, shopping lists, family inventory, and, in its final versions, added home temperature control and the ability to control appliances. In 1975, it was the turn of the Altair 8800, followed by the Apple II in 1977 and the IBM PC in 1981. While these computers were slowly finding their ways into the home, they also contributed to the creation of the idea of “smart machines”. In 1978, after a few years of experimentation and refinement, PICO Electronics patented the X10 technology. This technology can be considered the first “home network” as, differently to other networks available at the time, it enabled the existing electrical wiring in anyone’s home to also be used as the media for the communication network. By doing so, X10 made home automation a reality for the majority of the household at an affordable price. Nowadays, an increasing number of houses have home computers, game consoles and always-on Internet connections that extend the availability of services and resources to the household beyond the physical boundaries of the home.

## **2.5 SMART HOME TODAY**

The Oxford Dictionary defines “smart” as both “stylish and fresh in appearance, having a quick intelligence”, and “being fashionable and up market”. Sony was among the first companies to attach the “smart” buzzword to a computer when, in

1982, it marketed the “Smart Sony” computer: no longer advertised simply as a “home” computer, but tried to cash in on the smart concept by selling it as a device which could “help you make smarter business decisions” (Heckman, 2008). The “smart” concept has become since a marketing catchword, still employed today, to sell a wide range of products, hence:

“smart phones”, “smart cameras”, “smart design”, “smart bombs” and “smart homes”. Usually, the word define devices that are reportedly based on cutting-edge design that unite innovation with practical simplicity, However, as this would soon be demonstrated, sometimes marketing buzzwords alone cannot guarantee the sell. Xanadu was the first example of a mass-produced Smart Home. Built throughout the

1980s in the US around the original EPCOT idea, these houses were commercially built dwellings that made extensive use of Smart Home technologies. To look even more futuristic, the actual house was made entirely of polyurethane foam. The Xanadu home had a computer that monitored and controlled all its systems: the kitchen, living room, bathrooms, and bedrooms all had their own electrical and electronic devices to control the appliances present in the house. For example, the shower could be set to be turned on at a specific time and a set temperature. The ad campaign eloquently described the house as “Xanadu: the Computerized House of Tomorrow” and its peculiar appeal was set by the advertisement campaign: a “house with a brain – a house you can talk to, a house where every room adjusts automatically to match your changing moods” (Heckman, 2008). As the time moved on, and most of the houses were still unsold, the technology contained soon became obsolete. One by one, these Xanadu houses started to get demolished to make space for more “commercially viable” projects and, by October 2005, they were all gone. In spite of the commercial setback provided by the Xanadu homes, the concept was sound and a combination of elements such as computers, robotics and Artificial Intelligence (AI) were to push the Smart Home concept further, even if sometimes only in research laboratories. Throughout the 1980s, several innovative ideas provided a clear indication that the technology might have been finally mature enough to deliver commercially viable solutions. As an example, a device named Waldo, which interfaced with an Apple computer, could use voice recognition and speech synthesis technology to control appliances.

### 2.5.1 Aspects of Automatic Speech Recognition (asr) Device

Automatic speech recognition (ASR) is the process by which a computer maps an acoustic speech signal to some form of abstract meaning of the speech. Automatic speech recognition (ASR) applications focus on public services such as operator automatic operator assistance voice activated information retrieval, voice doing and many other similar tasks. Speech recognition should not be confused with a dial tone (DTMF) application where the user must select from numbered options or spell out and account number using the telephone keypad. A speech recognition application allows the user to answer questions and

provide information using a normal speaking voice many companies have already invested easily in human powered call centres or DTMF (touch- tone) interactive voice response (IVR) systems. They are changing or adapting to ASR applications, because of cost savings and improvement in customer satisfaction and experience. It has been shown that automatic speech recognition application are far more popular with callers than DTMF menu systems. In general, ASR system consist of

- (i) A signal processing front-end
- (ii) Acoustic modelling
- (iii) Language modelling

## **2.6 TECHNICAL DETAILS OF GSM**

GSM is a cellular network, which means that mobile phone can be connected to it by searching for cells in the immediate vicinity. GSM network operate in four different frequency ranges. Most GSM network operates in the 900MHz or 1800 MHz bands. In 900 MHz band, the uplink frequency band is between 890-915 MHz and the downlink frequency band is 935-960 MHz. In the 1800mhz band, the uplink frequency is between 1710-1785 MHz and the downlink is between 1805-1880MHz. also in 1900 MHz band, the uplink frequency band is 1850 Mhz- 1950 MHz. In GSM 900 MHz, the band allocation is 25 MHz band width which is subdivided into 24 carrier frequency channels, each spaced 200 kHz apart. Time division multiplexing is used to allow eight-half rate to sixteen half-rate speech channels per radio frequency channel. There are eight-radio time slots (giving eight burst penods) grouped into what is called TOMA frame. Half rate channels use alternate frames in the same time slot. The channels data rate is 270 833kbit/s and the frame duration is 4.615ms. The transmission power in the handset is limited to a maximum of 2 crafts in GSM 900 and I waH in GSM 1800/1900. GSM has used a variety of voice codes.

### 2.13 Subscriber Identity Modula (sim) as a GSM feature

One of the key features of GSM is the subscriber identity module (SIM). It is usually known as Sim card. The Sim is detachable smart in appearance and is used for the subscription of information and phonebook. This allows the retrieval of information after switching handset on. The Sim card also enables users to link each other irrespective of different network operation. For the purpose of this project work to be achieved a Sim card on any network is required to establish a link between a user and its household equipment to squeeze 3.1Kh2 audio between 5.6 and 13kbits/s.

## CHAPTER THREE

### 3.1 MATERIALS AND METHODS

### 3.2 DESCRIPTION OF COMPONENTS

A lot of components were used to implement this project. Below are the list of components used in a bid to achieve the proposed project.

Table 3.1: Table of components

Serial No	Components	Quantity
1	MT8870DE	1
2	Transformer	1
3	5V Regulator	1
4	12V Regulator	1
5	Bridge Rectifier	1
6	MODEM(Nokia 1280)	1
7	Heat Sink	2
8	Relays	9
9	CD7414	6
10	CD74154	1
11	Light Emitting Diode(LED)	12
12	Mobile Speaker port	1
13	Mobile MIC Port	1
14	Power Switch	1
15	Crystal Oscillator	1
16	Diodes	12

17	Capacitors(10 $\mu$ f,1nf,100nf)	14
18	Resistors(1k $\Omega$ ,10k $\Omega$ ,47k $\Omega$ )	42
19	Transistors(BC545)	9
20	Electrical socket	1
21	Mobile Phone	1

### 3.21 Component Description

#### 1) MT8870DE

##### **FEATURES**

- Full DTMF receiver
- Less than 35mW power consumption
- Industrial temperature range
- Uses quartz crystal or ceramic resonators
- Adjustable acquisition and release times
- 18-pin DIP, 18-pin DIP EIAJ, 18-pin SOIC, 20-pin PLCC

##### **DESCRIPTION**

The MT8870 provides full DTMF receiver capability by integrating both the band-split filter and digital decoder functions into a single 18-pin DIP, SOIC, or 20-pin PLCC package. The MT8870DE/70C is manufactured using state-of-the-art CMOS process technology for low power consumption (35mW, MAX) and precise data handling. The filter section uses a switched capacitor technique for both high and low group filters and dial tone rejection. The



MT8870DE/70C decoder uses digital counting techniques for the detection and decoding of all 16 DTMF tone pairs into a 4-bit code. This device contains input protection against damage due to high static voltages or electric fields; however, precautions should be taken to avoid application of voltages higher than the maximum rating.

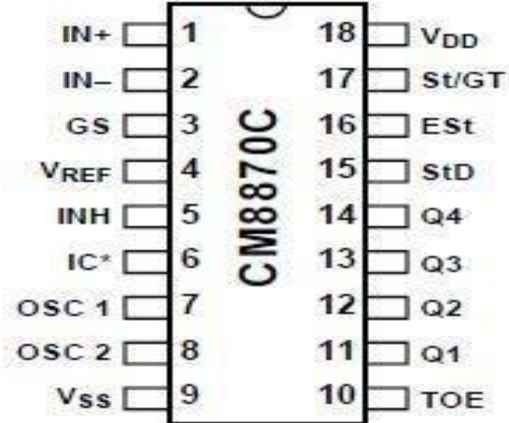

Fig. 2: PIN DIAGRAM

**PIN CONFIGURATION**

**IN+:** Non-inverting

**IN-:** Inverting

**GS:** Gain select

**VREF:** Reference Output Voltage (nominally VDD/2)

**INH:** Inhibits

**OSC3:** Digital buffered oscillator output

**PD:** Power down

**OSC1:** Clock input

**OSC2:** Clock output

**VSS:** Negative power supply

**TOE:** Three-state output enables (Input)

**Q1:** Three-state outputs

**Q2, Q3, Q4:** Tone pair received

**StD:** Delayed Steering output

**ESst:** Early steering output

**St/Gt:** Steering input/guard

**VDD:** Positive power supply

**IC:** Internal connection

## **2) TRANSFORMER**

### **Principle of the transformer**

Two coils are wound over a Core such that they are magnetically coupled. The two coils are known as the primary and secondary windings. In a Transformer, an iron core is used. The coupling between the coils is source of making a path for the magnetic flux to link both the coils. A core as in fig.2 is used and the coils are wound on the limbs of the core. Because of high permeability of iron, the flux path for the flux is only in the iron and hence the flux links both windings. Hence there is very little „leakage flux“. This term leakage flux denotes the part of the flux, which does not link both the coils, i.e., when coupling

is not perfect. In the high frequency transformers, ferrite core is used. The transformers may be step-up, step-down, frequency matching, sound output, amplifier driver etc. The basic principles of all the transformers are same.

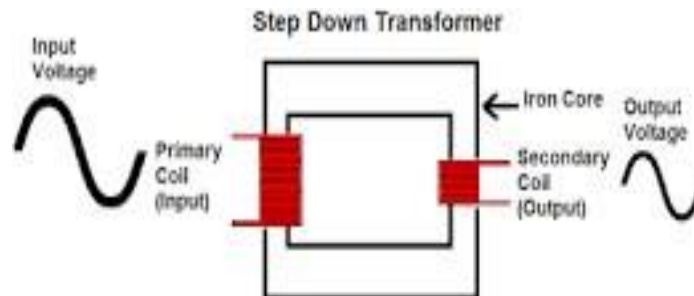

**Fig.3: Transformer**

## **VOLTAGE REGULATOR**

### **FEATURES**

- Output current in Excess of 1.0 A
- No external component required
- Internal thermal overload protection
- Internal short circuit current limiting
- Output transistor safe-area compensation
- Output voltage offered in 2% and 4% tolerance
- Available in surface mount D2PAK and standard 3-lead transistor packages
- Previous commercial temperature range has been extended to a junction temperature range of -40 degree C to +125 degree C.

### **DESCRIPTION**

Voltage regulator ICs are available with fixed (typically 5, 12 and 15V) or variable output voltages. The maximum current they can pass also rates them. Negative voltage regulators are available, mainly for use in dual supplies. Most regulators include some automatic protection from excessive current and

overheating (thermal protection). Many of fixed voltage regulator ICs has 3 leads. They include a hole for attaching a heat sink if necessary.



**Fig 4: voltage regulator**

#### **4) BRIDGE RECTIFIER**

Bridge rectifier circuit consists of four diodes arranged in the form of a bridge as shown in the figure below.

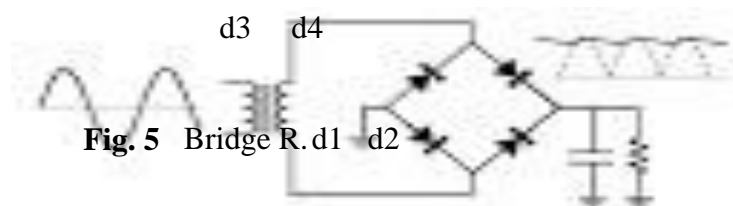

**Fig. 5** Bridge R. d1 d2

#### **OPERATION**

During the positive half cycle of the input supply, the upper end of the transformer becomes positive with respect to its lower point. This makes one end of the bridge rectifier positive. The diode D1 & D4 become forward biased & D3 & D2 become reverse biased. As a result, current starts flowing from point 1, through D1 the load & D4 to the negative end. During negative half cycle, the other end becomes positive. Diodes D1 & D4 now become reverse biased.

## 5) MODEM (NOKIA 1280)

The MODEM is used to decode the DTMF tone so that each Relay can be activated accordingly. But in this case, a mobile phone, precisely NOKIA 1280 is used here as a MODEM. Any mobile phone can be used but must be set to automatic answer.



**Fig. 6: A phone**

## 6) HEAT SINK

Heat sink is meant to conduct the heat generated by the IC away from the IC so as to prevent the IC from overheating or getting burnt.

## 7) RELAY

Relay is an electromechanical device with solenoid and mechanical switch. The solenoid is an electromagnetic device when voltage is applied to its inductor it become an electromagnet (temporal magnet), when the applied voltage is remove it loses its magnetic properties (Induction will occur). To prevent this inductive kick back, a diode is connected across the inductive load if it is operating in a dc power system. The switch used in this project has a normally open and a normally-close contact switches which is called a single pole double throw switch, which is the mechanical part. Below is circuit symbol of a relay.

### 8) CD7414

The CD7414 is made up of six Inverters encapsulated in a package. This IC is used to invert the signal generated by CD74154. Below is the pin diagram of CD7414.

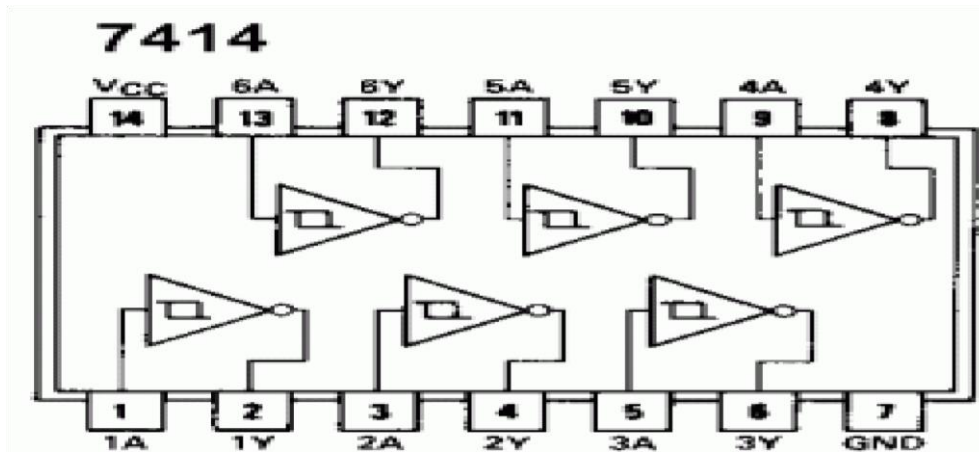
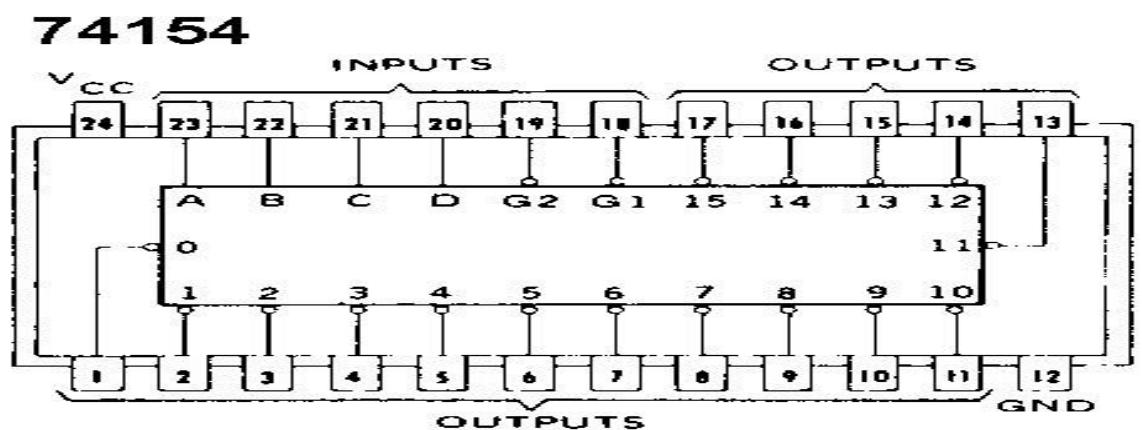

Fig. 7: CD7414

### 9) CD74154

This is a 4-line-to-16 line decoder, it takes signal(s) generated by MT8870 and spread it to the output (i.e. one output is activated at a time). The diagram below shows the pin out of the IC CD74154.

Fig. 8: 74154



## 10) LIGHT EMITTING DIODE (LED)

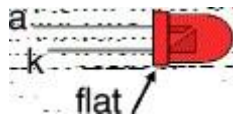

Fig 9: LED

LED falls within the family of P-N junction devices. The light emitting diode (LED) is a diode that will give off visible light when it is energized. In any forward biased P-N junction there is, with in the structure and primarily close to the junction, a recombination of hole and electrons. This recombination requires that the energy possessed by the unbound free electron be transferred to another state. The process of giving off light by applying an electrical source is called electroluminescence.

LED is a component used for indication. All the functions being carried out are displayed by led .The LED is diode which glows when the current is being flown through it in forward bias condition. The LEDs are available in the round shell and also in the flat shells. The positive leg is longer than negative leg.

## 11) CRYSTAL OSCILLATOR

Crystal oscillators are oscillators where the primary frequency determining element is a quartz crystal. Because of the inherent characteristics of the quartz crystal the crystal oscillator may be held to extreme accuracy of frequency stability. Temperature compensation may be applied to crystal oscillators to improve thermal stability of the crystal oscillator. Crystal oscillators are usually, fixed frequency oscillators where stability and accuracy are the primary considerations. For example it is almost impossible to design a stable and accurate LC oscillator for the upper HF and higher frequencies without

resorting to some sort of crystal control. Hence the reason for crystal oscillators. The frequency of older FT-243 crystals can be moved upward by crystal grinding.

## 12) DIODE

The diode is a p-n junction device. Diode is the component used to control the flow of the current in any one direction. The diode widely works in forward bias.

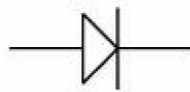

**Fig 10:** Diode

When the current flows from the P to N direction. Then it is in forward bias. The Zener diode is used in reverse bias function i.e. N to P direction. Visually the identification of the diode's terminal can be done by identifying the silver/black line. The silver/black line is the negative terminal (cathode) and the other terminal is the positive terminal (anode).

## 13) CAPACITOR

In a way, a capacitor is a little like a battery. Although they work in completely different ways, capacitors and batteries both store electrical energy. If you have read How Batteries Work, then you know that a battery has two terminals. Inside the battery, chemical reactions produce electrons on one terminal and absorb electrons at the other terminal.

### BASIC

Like a battery, a capacitor has two terminals. Inside the capacitor, the terminals connect to two metal plates separated by a dielectric. The dielectric can be air, paper, plastic or anything else that does not conduct electricity and keeps the plates from touching each other. You can easily make a capacitor from



two pieces of aluminium foil and a piece of paper. It won't be a particularly good capacitor in terms of its storage capacity, but it will work. In an electronic circuit, a capacitor is shown like this:

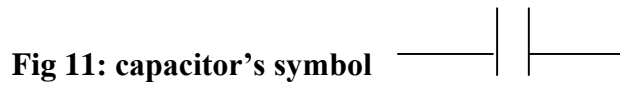

#### 14) RESISTOR

The flow of charge through any material encounters an opposing force similar in many respects to mechanical friction. This opposing force is called resistance of the material. In some electric circuit resistance is deliberately introduced in form of resistor. Resistors used fall in three categories, only two of which are colour coded which are metal film and carbon film resistor. The third category is the wire wound type, where values are generally printed on the vitreous paint finish of the component. Resistors are in ohms and are represented in Greek letter omega, looks as an upturned horseshoe. Most electronic circuit requires resistors to make them work properly and it is obviously important to find out something about the different types of resistors available. Resistance is measured in ohms; the symbol for ohm is an omega ohm. 1 ohm is quite small for electronics so resistances are often given in  $k\Omega$  and  $M\Omega$ . Resistors used in electronics can have resistances as low as 0.1 ohm or as high as 10  $M\Omega$ .

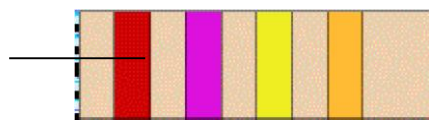

**Fig. 12** Resistor

#### 15) TRANSISTOR

The transistor is one of the fundamental building blocks of modern electronic devices, and is ubiquitous in modern electronic systems. Following its release in the early 1950s the transistor revolutionized the

field of electronics and paved way for smaller and cheaper radios, calculators and computers amongst other things.

A transistor is a semiconductor device used to amplify and switch electronic signals. It is made of a solid piece of semiconductor material with at least three terminals for connection to an external circuit. A voltage or current applied to one pair of the transistor's terminals, changes the current flowing through another pair of terminals. Since the controlled (output) power can be much more than the controlling (input) power, the transistor provides amplification of a signal. Today, some transistors are packaged individually but many more are found embedded in integrated circuits.

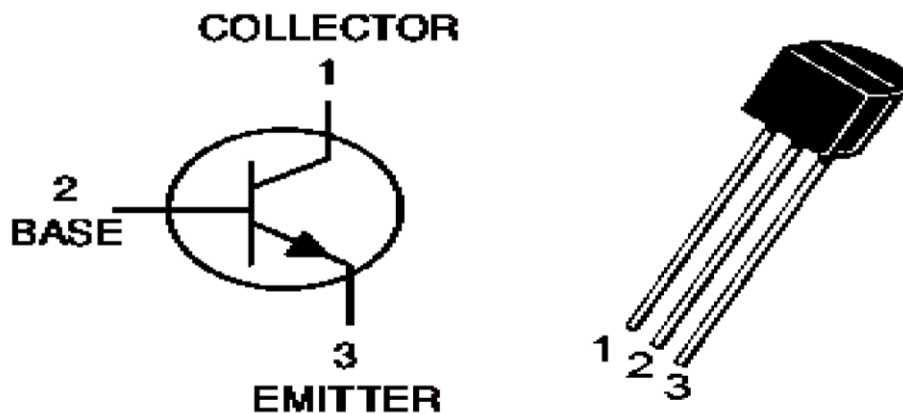

**Fig13: Transistors**

### **16) GSM MODULE:**

GSM module is used in many communication devices which are based on GSM (Global System for Mobile Communications) technology. It is used to interact with GSM network using a computer. GSM module only understands AT commands, and can respond accordingly. The most basic command is “AT”, if GSM respond OK then it is working good otherwise it respond with “ERROR”. There are various AT commands like ATA for answer a call, ATD to dial a call, AT+CMGR to read the message, AT+CMGS to send the sms etc. AT commands should be followed by Carriage return i.e. \r (0D in hex), like “AT+CMGS\r”. We can use GSM module using these commands:

ATE0 - For echo off

AT+CNMI=2,2,0,0,0 <ENTER> - Auto opened message Receiving. (No need to open message)

ATD<Mobile Number>; <ENTER> - making a call (ATD+919610126059;\r\n) AT+CMGF=1  
<ENTER> - Selecting Text mode

AT+CMGS="Mobile Number" <ENTER> - Assigning recipient's mobile number

>>Now we can write our message

>>After writing message

Ctrl+Z send message command (26 in decimal).

ENTER=0x0d in HEX

The SIM900 is a complete Quad-band GSM/GPRS Module which delivers GSM/GPRS 850/900/1800/1900MHz performance for voice, SMS and Data with low power consumption.



FIG. 14 GSM MODULE

### **3.3 PHYSICAL DESCRIPTION OF TRANSISTORS**

The two types of transistors have slight differences in how they are used in a circuit. A bi-polar transistor has terminals labelled base, collector and emitter. A small current at the base terminal (i.e. flowing from the base to the emitter) can control or switch a much larger current between the collector and emitter terminals. For a field effect transistor (FET), the terminals are labeled gate, source and drain; a voltage at the gate can control current between source and drain.

#### **3.3.1 Principle of Operation**

Transistors are commonly used as electronic switches for both high power applications including switched mode power supplies and low power applications such as logic gates. In grounded emitter transistor circuit, as the voltage rises, the base and collector current rises exponentially and the collector voltage drops because of the collector load resistor. For the transistor to act as a switch, the values of the input voltage can be chosen such that the output is completely on (at saturation) or completely off. This type of operation is common in digital circuits where only “on” and “off” values are relevant.

#### **3.3.2 Hardware Subsystems**

The project was designed and implemented using top to bottom design method just as shown in the block diagram in figure 3.1. The system starts form the following Units:-

- GSM module unit
- Peripheral interface control (P.I.C) unit

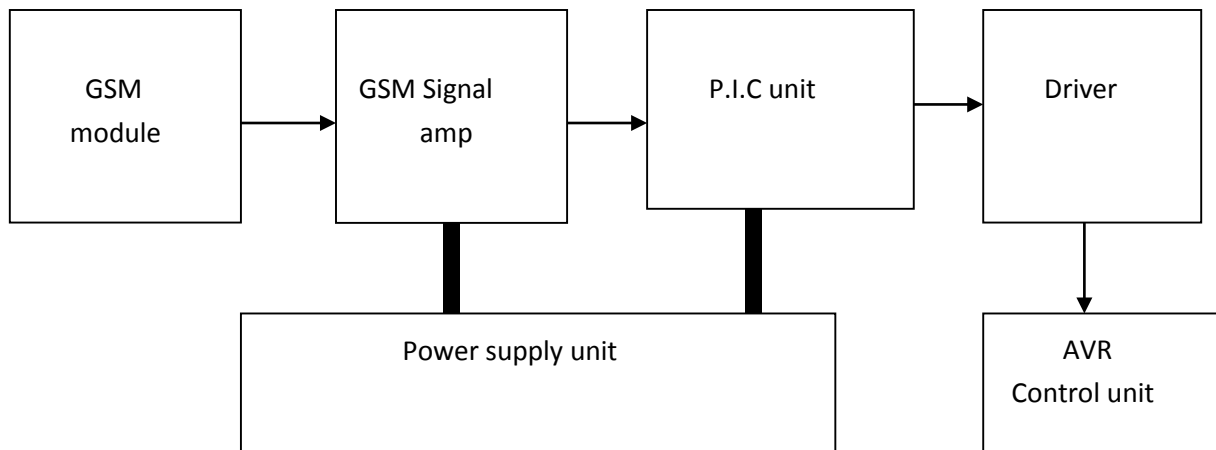

• Fig.15: CBD

- Power surge monitoring and control unit , (AVR)

In the methodology, the overall system design is in two parts: hardware design and software design. The hardware design is the physical parts of the system while the software design treats the programs that were written to control the microcontroller at the processing centre of the system. The hardware design is the heart of the project. This is the physical implementation where the various components used for the design were incorporated together on a Vero board through soldering. It consists of many units which includes a GSM module, a PIC unit and other units listed above.

### 3.4 SYSTEM ANALYSIS AND DESIGN

The system uses GSM signal system which allows its users to effectively control their house/office appliances simply by calling the device.

The call receive by the device is processed by a microcontroller to perform an OFF operations.

The type of the operation performed is based on the nature of the GSM signal sent. An encoded GSM signal is generated and sent from the GSM base station to the device.

In this project two GSM module are involved:

- The GSM transmitter module which is the users cell phone

- The GSM receiver module which is the cell phone connected to the

Project.

There are lots of remote controls methodology like infrared, RF, SMS and more but in this project I prefer the calling system using GSM network. SMS control system uses the GSM network as well but the problem with it is that SMS sometimes does not arrive on time. In the design methodology, GSM network was used because of its wider coverage.

The relay driver is used to drive the relay circuits which switches the different appliances connected to the output of the project.

The figure shown above is the schematic diagram of our project. It is a simple illustration of how we have implemented our project and the various parts involved in it. From the above representation, the first Mobile station is used as a transmitting section from which the subscriber makes a call which is the command or instruction for the second mobile station. A SIM card is inserted in the receiver cell phone.

### **3.5 CIRCUIT DESCRIPTION**

Connections of this GSM based home automation circuit are quite simple, here a liquid crystal display is used for displaying status of home appliances which is directly connected to arduino in 4-bit mode. Data pins of LCD namely RS, EN, D4, D5, D6, D7 are connected to arduino digital pin number 6, 7, 8, 9, 10, 11. And Rx and Tx pin of GSM module is directly connected at Tx and Rx pin of Arduino respectively. And GSM module is powered by using a 12 volt adaptor. 5 volt SPDT 3 relays are used for controlling LIGHT, FAN and TV. And relays are connected to arduino pin number 3, 4 and 5 through relay driver ULN2003 for controlling LIGHT, FAN and TV respectively.

## Circuit Diagram

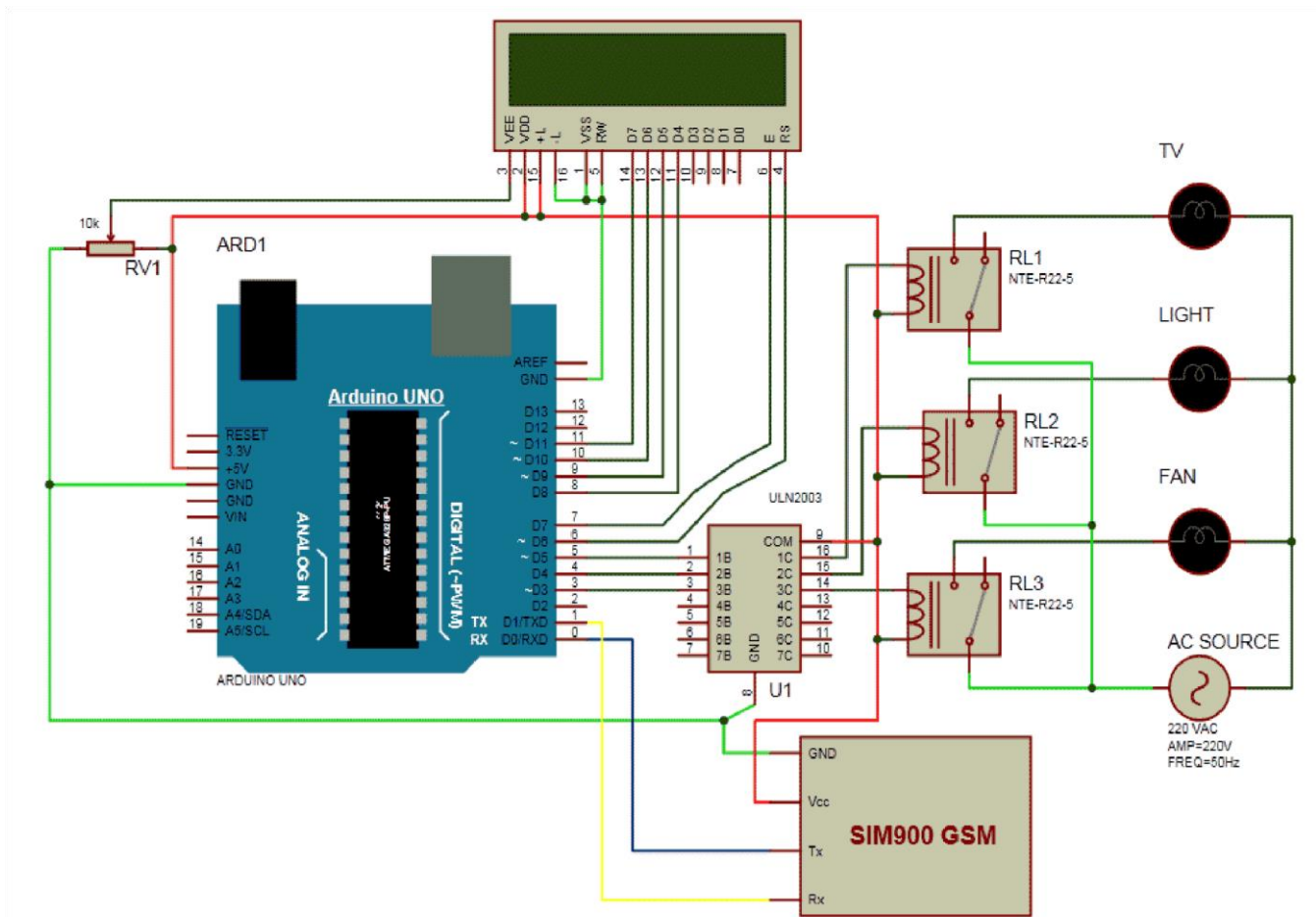

Fig 16 Circuit Diagram of the Project

### 3.6 CODE/PROGRAMM DESCRIPTION

In programming part of this project, first of all in programming we includes library for liquid crystal display and then we defines data and control pins for LCD and home appliances.

```
#include<LiquidCrystal.h>
```

```
LiquidCrystal lcd(6,7,8,9,10,11);
```

```
#define Fan 3
```

```
#define Light 4
```

```
#define TV 5
```

```
int temp=0,i=0; int  
led=13;
```

After this serial communication is initialized at 9600 bps and gives direction to used pin. void setup()

```
{  
  
  lcd.begin(16,2);  
  Serial.begin(9600);  
  pinMode(led, OUTPUT);  
  pinMode(Fan, OUTPUT);  
  pinMode(Light, OUTPUT);  
  pinMode(TV, OUTPUT);
```

For receiving data serially we have used two functions one is Serial.available which checks whether any serial data is coming and other one is Serial.read which reads the data that comes serially.

```
while (Serial.available())  
  
  {  
  
    char inChar=Serial.read();
```

After receiving data serially we have stored it in a string and then waiting for Enter. Void serialEvent()

```
{  
  
  while(Serial.available())  
  
  {  
  
    if(Serial.find("#A."))  
  
    {
```



```

    digitalWrite(led, HIGH);
    delay(1000);
digitalWrite(led, LOW);
while (Serial.available())

    {

        char inChar=Serial.read();
str[i++]=inChar;
if(inChar=='*')

        {

            temp=1;
return;

        }

```

When Enter comes program start to compare received string with already defined string and if string matched then a relative operation is performed by using appropriate command that are given in code.

```

void check()

{

    if(!(strcmp(str,"tv on",5)))

        {

            digitalWrite(TV, HIGH);
lcd.setCursor(13,1);
lcd.print("ON  ");
delay(200);

        }

    else if(!(strcmp(str,"tv off",6)))

        {

```

```
digitalWrite(TV, LOW);  
lcd.setCursor(13,1);    lcd.print("OFF ");  
delay(200);  
  
}
```

c

### 3.7 TRANSFORMER

The step down transformer is an electrical device that steps down voltage and current in a circuit. It receives its input power source from the 220v ac mains supply and steps it down to 12v. The transformer primary is shown connected only to the line cord and plug in which the first block diagram represents. This power supply is double-insulated. There is no electrical connection between the primary and secondary sides of the transformer so most jurisdictions do not require a grounding plug. Figure 3.2 shows the picture of transformer used in the project.

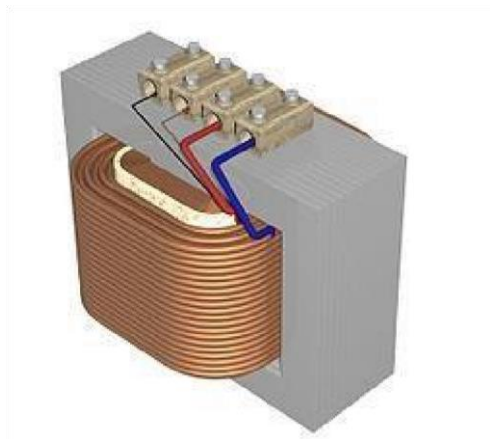

**Fig 17:** Transformer

The voltage induced across the secondary coil may be calculated from Faraday's law of induction, which states that:

$$V_s = N_s \frac{d\Phi}{dt}$$

Where  $V_s$  is the instantaneous voltage,  $N_s$  is the number of turns in the secondary coil and  $\Phi$  is the magnetic flux through one turn of the coil. If the turns of the coil are oriented perpendicularly to the magnetic field lines, the flux is the product of the magnetic flux density  $B$  and the area  $A$ , through which it cuts. The area is constant, being equal to the cross-sectional area of the transformer core, whereas the magnetic field varies with time according to the excitation of the primary. Since the same magnetic flux passes through both the primary and secondary coils in an ideal transformer, the instantaneous voltage across the primary winding equals

$$V_p = N_p \frac{d\Phi}{dt}$$

Taking the ratio of the two equations for  $V_s$  and  $V_p$  gives the basic equation for stepping up or stepping down the voltage

$$\frac{V_s}{V_p} = \frac{N_s}{N_p}$$

$N_p/N_s$  is known as the turn ratio, and is the primary functional characteristic of any transformer. In the case of step-up transformers, this may sometimes be stated as the reciprocal,  $N_p/N_s$ . Turns ratio is commonly expressed as an irreducible fraction or ratio: for example, a transformer with primary and secondary windings of, respectively, 100 and 150 turns is said to have a turns ratio of 2:3 rather than 0.667 or 100:150.

### 3.8 REGULATION UNIT/DESIGN CALCULATION

Regulation is a measure of the difference in voltage provided by the transformer's secondary winding when it is on load and off load. It is expressed as a percentage relative to the full load voltage and, basically, the lower the value, the less the voltage difference. Strictly speaking, the transformer's datasheet (or supplier) should state the output voltage when the transformer is under its full rated load.

For example, a transformer rated at 12v, 50VA should provide 12v to a load which takes 4 amps.

$50VA \text{ at } 12volts = 50/12 = 4.1 \text{ Amps}$  Our transformer provides 12.5 volts off load so, unless the regulation is exceptionally good, the "nominal" 12 volts hasn't been specified as the on-load voltage at all.

$$\% \text{ regulation} = \frac{\text{off load voltage} - \text{on load voltage}}{\text{on load voltage}} \times 100$$

$$= \frac{12.5 - 12}{12} \times 100$$

$$= 4\%$$

Later tests proved that the output voltage dropped to less than 11.4 volts when presented with a load of just 2 Amps. At best, this is a regulation of around 14% even at just 2 Amps. The disadvantage of using a transformer with too high an output voltage is that the regulator will need to work harder and dissipate even more surplus energy and, as the maximum off load voltage will be higher, the voltage monitoring circuit will need to take the higher voltage into account. **NEON LIGHT:** A red neon light indicator and voltage meter is used in this project to indicate when there is voltage supply in the system and when the

system shutdown the house appliances. A neon light is a solid-state lamp that emits light just as a light-emitting diode.

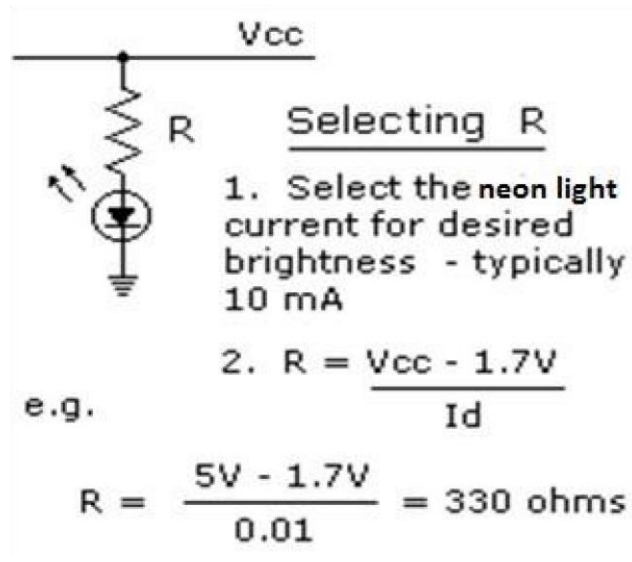

**Fig1.16**

The resistance of the neon light is 330 ohms while the voltage is 3v.

### 3.10 The Power Supply

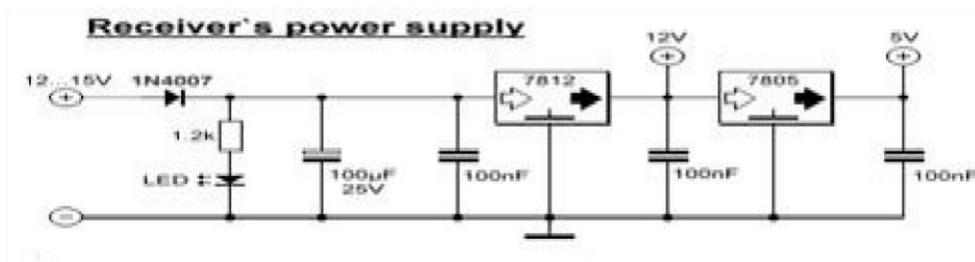

**Fig: 18: The power supply or receiver**

The power supply of this project is constituted by 2 voltage regulator; LM7812 and LM7805.

The first 12V is only to power the relay and the second 5V is to power the microcontroller.

### **3.9**

## **THE MICROCONTROLLER**

The microcontroller used in this project is the ATMEGA16A PU 1426H. Its pins are shown below.

**Fig. 19: microcontoller**

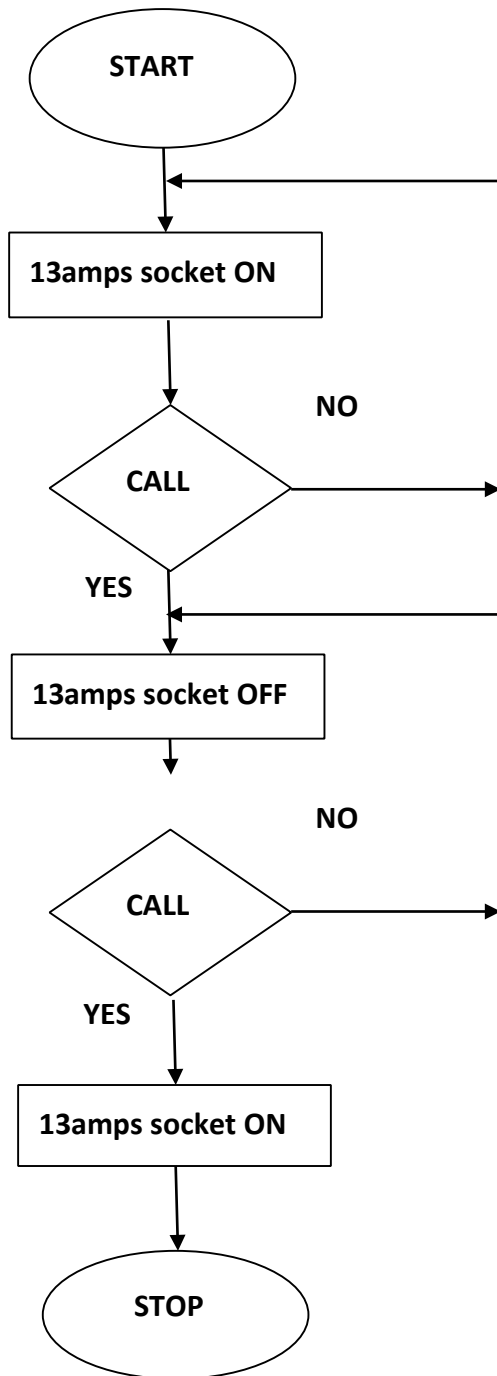
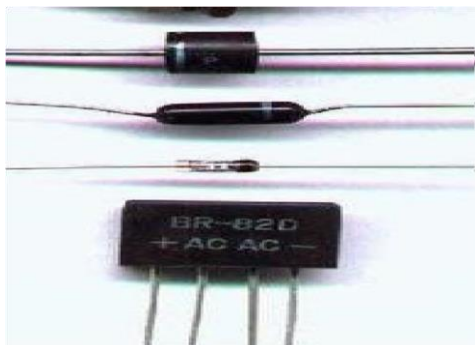

**Fig 20: Flow Chart of the system**

The process to operate this project is first make a mobile to mobile connection wirelessly or with a single mobile on-board wired. But here we are using two mobiles to make a wireless application. Start with making a connection with the on-board mobile from a remote distance, then when connection is established lets control the project with the data as follows:

To control appliances, make a “CALL”, to switch ON, and also, to switch OFF again, make another “CALL”. This ON/OFF condition of the device is through the Relay, where switching is very fast and accurate.

**DIODES:** A diode plays an important role in the project. It allows the battery voltage to flow into the circuit only in one direction (called the diode's forward bias direction) and also block any back electromotive force that may damage the driver transistors. The diode is a twoterminal electronic component with a nonlinear current–voltage characteristic. This unidirectional behaviour of diode is called rectification and it is used in the project to convert alternating current from the GSM Module to direct current which is used to bias the switch transistor used in the project.



Picture of four types of diodes **Fig 21**

**CAPACITOR:** Capacitors are used in the project to blocking direct current from the GSM Module and allow alternating signal to pass into the system. It is also used for filtration and smoothing of unwanted A.C ripples in the power supply unit. A capacitor is a passive component consists of a pair of conductors separated by a dielectric (insulator). When there is a potential difference (voltage) across the conductors,



a static electric field develops across the dielectric, causing positive charge to collect on one plate and negative charge on the other plate.



Picture of the electrolytic capacitor Fig 22

**RESISTORS:** A resistor is used to bias the switching transistor that energizes the relay. It also used to limit the amount of current flowing into the project. A linear resistor is a linear component that implements electrical resistance as a circuit element. The current through a resistor is in direct proportion to the voltage across the resistor's terminals. Thus, the ratio of the voltage applied across a resistor's terminals to the intensity of current through the resistor is called resistance. This relation is given by

$$I = \frac{V}{R}$$



**Fig. 21: Resistor**

**RELAY/CONTACTORS:** Relay is the main control switch that shutdown the house appliances when a call is made. A relay is an electromagnetic operated switch. Current flowing through the coil of the relay creates a magnetic field, which attracts a lever and changes the switch contacts. The coil current can be on or off so relays have two switch positions and they are double throw switches. To prevent damage to

the relay a diode must be connected across the relay coil. The relay's switch connections are usually labelled **COM, NC and NO**:

Table 3.1: Pin Configuration and meaning

PIN CONFIGURATION	MEANING
<b>COM</b>	Common, always connect to this; it is the moving part of the switch
<b>NC</b>	Normally closed, COM is connected to this when the relay coil is off.
<b>NO</b>	Normally open, COM is connected to this when the relay coil is on.

**3.10 RELAYS AND TRANSISTORS COMPARED**

Like relays, transistors can be used as an electrically operated switch. For switching small DC currents (< 1A) at low voltage they are usually a better choice than a relay. However, transistors cannot switch AC (such as mains electricity) and in simple circuits they are not usually a good choice for switching large currents (> 5A). In these cases a relay will be needed, but note that a low power transistor may still be needed to switch the current for the relay's coil! The main advantages and disadvantages of relays are listed below:

### **ADVANTGES OF RELAYS:**

- Relays can switch AC and DC, transistors can only switch DC.
- Relays can switch higher voltages than standard transistors.
- Relays are often a better choice for switching large currents ( $>5A$ ).
- Relays can switch many contacts at once.

### **DISADVANTAGES OF RELAYS:**

- Relays are bulkier than transistors for switching small currents.
- Relays cannot switch rapidly (except reed relays), transistors can switch many times per second.
- Relays use more power due to the current flowing through their coil. Relays require more current than many ICs can provide, so a low power transistor may be needed to switch the current for the relay's coil.

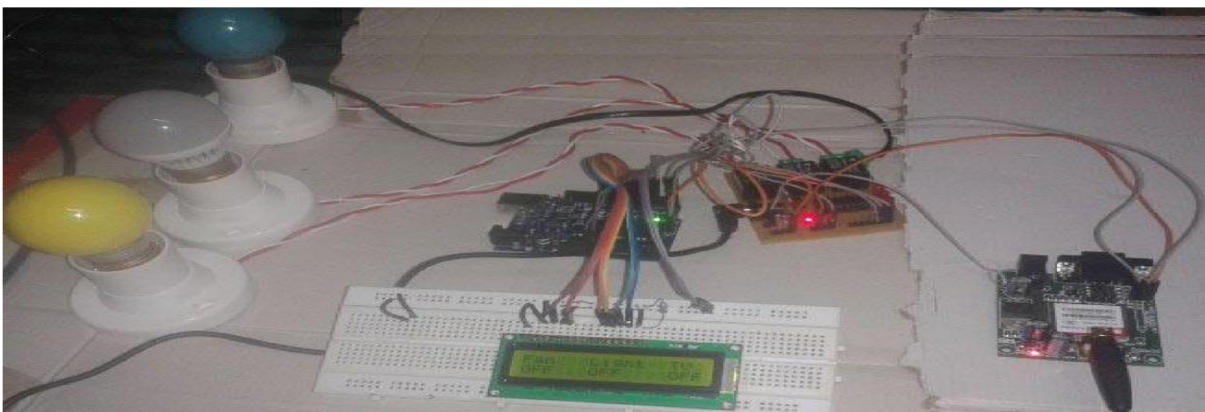

Fig. 24: design setups

## CHAPTER FOUR

### 4.1 SYSTEM IMPLEMENTATION AND PROJECT COSTING

### 4.2 CONSTRUCTION

The term stage is associated to a group of components, which is aimed at achieving a specific purpose. This has been broken down in the previous chapter. Each of the stage will now be treated more elaborately. Meanwhile, the block diagram and circuit of the project is shown below:

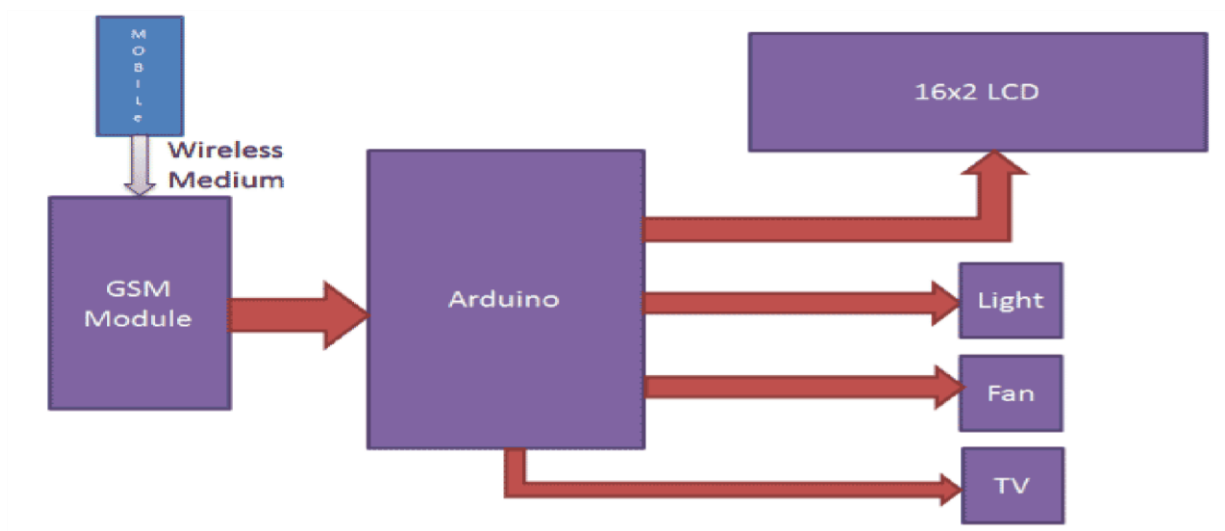

**Fig. 25: operational block diagram**

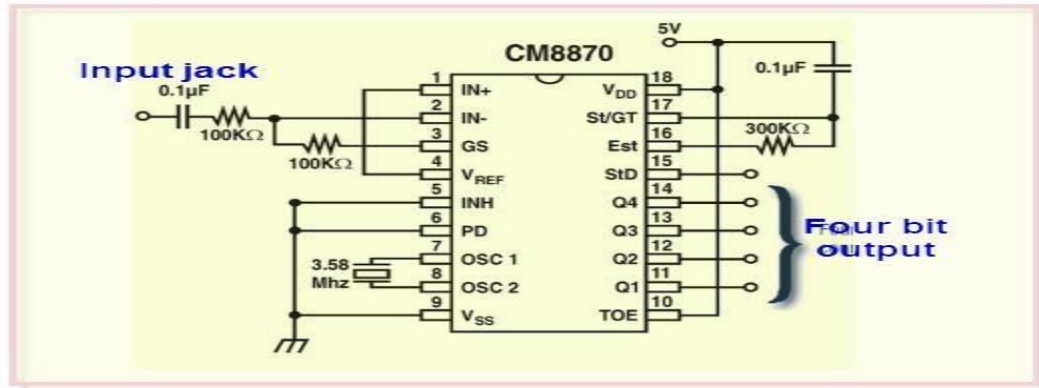

**Fig. 26: micro-chip**

#### 4.2.1 Constructional Method

The construction of this project was done on a Vero board. Vero board is called strip board. It is a widely-used type of electronics prototyping board characterized by a 0.1 inch (2.54 mm) regular (rectangular) grid of holes, with wide parallel strips of copper cladding running in one direction all the way across one side of the board. In using the board, breaks are made in the tracks, usually around holes, to divide the strips into multiple electrical nodes. With care, it is possible to break between holes to allow for components that have two pin rows only one position apart such as twin row headers for ICs.

### 4.3 POWER SUPPLY UNIT [PSU]

The transformer is connected to the mains of 220v/50Hz through a power cord of resistance. The transformer's (12v/500mA) secondary output is connected to the bridge rectifier source inputs. An output is taken from the negative and positive terminals of the rectifier and connected to the corresponding pins in the 1000uF/35v capacitor. This bridge rectifier the supply while the capacitor filters the A.C voltage lefts and equally smoothens the signal into a pure D.C voltage of 12vDC. The positive terminal of the capacitor is connected to pin 1 of the 7805 voltage regulator, while the negative terminal connects to pin 2 of the regulator. This regulator produces an output of +5v between pin 3 and pin 2(Ground).

**Vero board:** The construction of this project was done on a vero board and the procedure methods used are: -

1. The vero board was inspected of wrong linkages of its line which may be mistake from the producers. The holes of the board were made sure to be through for passing the terminals of the components for soldering.
2. An abrasive paper was used on the soldering section of the board for easy binding of the terminals on the board.



**Fig. 27: Vero board**

### **The picture of the Vero board used in the project**

Components are usually placed on the plain side of the board, with their leads protruding through the holes. The leads are then soldered to the copper tracks on the other side of the board to make the desired connections, and any excess wire is cut off. The continuous tracks may be easily and neatly cut as desired to form breaks between conductors using a 5mm twist drill, a hand cutter made for the purpose, or a knife. Tracks may be linked up on either side of the board using wire. With practice, very neat and reliable assemblies can be created, though such a method is labour-intensive and therefore unsuitable for production.

#### **4.4 MOUNTING OF THE COMPONENTS**

Joining the supposed terminals together before soldering. And after soldering each unit, test was carried out using a meter to ensure good contact. A patrax box was used for the enclosure of the project. Patrax is an electrical installation box used for housing electrical/electronic components. It is made of plastic material, 50×20mm rectangular shape with 10mm thickness. This box houses the control unit.

#### **4.5 INTERCONNECTION OF COMPONENTS**

The interconnections of the circuit were done using a PVC connecting wire. This enabled the necessary connections at different sections of the circuit to be made by extending the terminals or connection made with a wire to a deserved point in the circuit. Connecting wires is a flexible wire made from copper and will be used to connect component or subsystems.



PVC wire **Fig. 28:**

Complete construction box of the project



#### 4.6 BILL OF ENGINEERING MATERIALS AND EVALUATION

S/N	COMPONENT	QUANTITY	UNITY	AMOUNT
			PRICE (₦)	(₦)
1	Diode (1N4001)	7	10	70
2	Arduino UNO	1	1	6,000
3	Resistors	12	5	60
4	Transistor BC337	6	20	120
5	GSM Module	1	1	7,500
6	78151C Regulator and 7805	1	30	60
7	PIC 12F629	1	200	200
8	12V, 30 AMPS Relay	5	150	750
9	Casing	1	2000	2000
10	Power Switch	1	250	250
	Electrical Socket	1	600	600

11	Output Socket	1	200	200
12	Copper clad board	1	20	1000
13	Fuse	1	10	20
14	Neon Light	1	50	50
15	Microcontroller	1	5000	5000
16	16x2 LCD	1	2000	2000
16	Transformer (both copper wire and core)	1	2000	2000
17	Relay 5 volt	5	100	500
17	Nuts and screw	6	5	230
18	ULN2003	1	1	4,000
19	Mobile Phone	1	6000	6000
20	Electrical Socket	1	600	600

21	Capacitors	3	200	600
22	Crystal Oscillator	1	4000	4000
23	Mobile Speaker Port	1	1000	1000
24	Mobile MIC port	1	1000	1000
25	CD7414	1	400	400
26	CD74154	1	400	400
27	Heat Sink	1	700	700
28	Bridge Rectifier	1	950	950
29	12V Regulator	1	200	200
30	5V Regulator	1	200	200
31	MT8870DE	1	650	650
32	Logistics[Travelling and Shipping of equipments]	*	*	10,000
33	TOTAL	*	*	59,310

## **CHAPTER FIVE: CONCLUSION, RECOMMENDATIONS AND CONSTRAINTS**

### **5.1 CONCLUSION**

The GSM based home automation using AVR was designed and constructed to CONTROL 230V $\pm$ 5% ac load. It is rated 2500VA 50Hz.

This project has really exposed me to the use of electronic component. To a large extent I have come to appreciate the theories learned over the years.

### **5.2 RECOMMENDATIONS**

It is a fact that this is not exhaustive. It can still be improved to get a more sensitive and precise output voltage control.

For this reason I recommend the following.

1. Two layers circuit board can be designed and used in place of single layer circuit board for easier soldering work and neatness.
2. Further research in the field of electronics switching will go a long way in getting better house control system.
3. Engineering students need early exposure to the use of electronic components for practical work; this will enable them to be more innovative.
4. The application of this project should be transferred to the various offices in this university
5. Solar and inverter should be introduced to replace the epileptic power supply system here in Nigeria.
6. The project application should be transferred to the industries

### **5.3 CONTRIBUTION TO KNOWLEDGE**

My contribution is that instead of achieving automation in our homes and industries using Iot as common, I have successfully used GSM to achieve this. The limitations on GSM is easily managed than that of Iot in that one will not be restricted to android phones and internet services, any phone will do the job provided it has call card. Thus, it makes it very possible for anyone with little or no technological know-how in IT to effectively automate his home.

### **5.4 MAJOR CONSTRAINTS**

Along the course of project completion I encountered various problems and obstacles. Not everything that I had planned went smoothly during the project development span.

Also I had a limited amount of time for its completion so I was under a certain amount of pressure as well. I had to start from the research phase at the beginning and needed to gain knowledge on all the devices and components that I had intended to use for the project. Other phases of the project included coding, debugging, testing, documentation and implementation and it needed certain time for completion so I really had to manage the limited time available to me and work accordingly to finish the project within the schedule.

#### **5.4.1 Constraints Considerations**

The following is a list of constraint considerations

- The controlled appliances will need an electrical control interface. This system is only capable of controlling electrical devices.
- The control module will need to be shielded against electrostatic discharges.

This will increase the reliability of the system.

- Solar and inverter backup for controlling unit can be implemented in case of power disruption.

## **5.5 TECHNOLOGY CONSIDERATIONS**

The considerations for this system will include a choice of networks, communication protocols and interfaces.

- ✓ Cellular Networks: The widely available networks are based on GSM. This network provides wide area coverage and can be utilized more cost-effectively for this project.
- ✓ Communication Protocols: The available communication protocol that we have used is phone call. The phone call is the most efficient because this project requires a cellular communication and limited data to be sent.
- ✓ I/O interfaces between microcontroller and devices: Serial I/O is considered as options for connection between the GSM receiver and the microcontroller. Using the microcontroller, a control circuit will be implemented to control the electrical appliances.

## REFERENCES

- Alkar, A. Z., & Buhur, U. (2005). *An Internet Based Wireless Home Automation System for Multifunctional Devices*. IEEE Consumer Electronics, 51(4), 1169-1174. Retrieved from <http://www.thaieei.com>
- Ciubotaru-Petrescu, B., Chiciudean, D., Cioarga, R., & Stanescu, D. (2006). *Wireless Solutions for Telemetry in Civil Equipment and Infrastructure Monitoring*. 3rd RomanianHungarian Joint Symposium on Applied Computational Intelligence (SACI) May 25-26, 2006. Retrieved from <http://www.bmf.hu>
- Conte, G., & Scaradozzi, D. (2003). *Viewing home automation systems as multiple agents systems*. RoboCUP2003,
- Delgado, A. R., Picking, R., & Grout, V. (2006) *Remote-controlled home automation systems with different network technologies*. Proceedings of the 6th International Network Conference (INC 2006), University of Plymouth, 11-14 July 2006, pp. 357-366. Retrieved from <http://www.newi.ac.uk>
- Douglas V. H. (1999). *Microprocessor and Interfacing – programming and hardware*. Tata McGraw Hill 2nd Edition
- Harper, R. (2003), *Inside the Smart Home*, Springer-Verlag, London, UK.
- Heckman, D. (2008), *A Small World. Smart Houses and the Dream of the Perfect day*, Duke University Press, London, UK.
- Jawarkar, N. P., Ahmed, V., Ladhake, S. A. & Thakare, R. D. (2008). *Micro-controller based Remote Monitoring using Mobile through Spoken Commands*. *Journal of Networks*, 3(2), 58-63. Retrieved from <http://www.academypublisher.com>
- Murthy, M. V. R. (2008). *Mobile based primary health care system for rural India*. W3C workshop on Role of Mobile Technologies in Fostering Social Development, Jun 2008.
- Potamitis, I., Georgila, K., Fakotakis, N., & Kokkinakis, G. (2003). *An integrated system for smart-home control of appliances based on remote speech interaction*. EUROSPEECH 2003, 8th European Conference
- Jelinek F. (1997). *Statistical Methods for Speech Recognition*. Massachusetts Institute of Technology, Cambridge.

John Iovine. (June 1995). *DTMF IR Remote Control System*.

Rabiner L.R, Juang B.H. (1986). *An introduction to HMMs. IEEE ASSP* Rabiner L.R., Juang B.H. (1993). *Fundamentals of Speech Recognition*.

Prentice Hall, Englewood Cliffs, N.J.

Robert L. Boylestad,,Louis Nashelsky. (1999). *Electronic Devices and Circuit Theory (Eight Edition)*.



## APPENDICES

### Appendix 1.1: Bill of Engineering Materials and Evaluation [BEME]

S/N	COMPONENT	QUANTITY	UNITY	AMOUNT
			PRICE (₦)	(₦)
1	Diode (1N4001)	7	10	70
2	Arduino UNO	1	1	6,000
3	Resistors	12	5	60
4	Transistor BC337	6	20	120
5	GSM Module	1	1	7,500
6	78151C Regulator and 7805	1	30	60
7	PIC 12F629	1	200	200
8	12V, 30 AMPS Relay	5	150	750
9	Casing	1	2000	2000
10	Power Switch	1	250	250

	Electrical Socket	1	600	600
11	Output Socket	1	200	200
12	Copper clad board	1	20	1000
13	Fuse	1	10	20
14	Neon Light	1	50	50
15	Microcontroller	1	5000	5000
16	16x2 LCD	1	2000	2000
16	Transformer (both copper wire and core)	1	2000	2000
17	Relay 5 volt	5	100	500
17	Nuts and screw	6	5	230
18	ULN2003	1	1	4,000
19	Mobile Phone	1	6000	6000

20	Electrical Socket	1	600	600
21	Capacitors	3	200	600
22	Crystal Oscillator	1	4000	4000
23	Mobile Speaker Port	1	1000	1000
24	Mobile MIC port	1	1000	1000
25	CD7414	1	400	400
26	CD74154	1	400	400
27	Heat Sink	1	700	700
28	Bridge Rectifier	1	950	950
29	12V Regulator	1	200	200
30	5V Regulator	1	200	200
31	MT8870DE	1	650	650
32	Logistics[Travelling and Shipping of equipment]	*	*	10,000

33	TOTAL	*	*	59,310
----	-------	---	---	--------

## Appendix 1.2: Programming/Code Used

Thus, the total CODE/PROGRAMMING DETAILS:

Code:

```
#include<LiquidCrystal.h>

LiquidCrystal lcd(6,7,8,9,10,11);

#define Fan 3

#define Light 4
#define TV 5
int temp=0,i=0;
int led=13; char
str[15]; void
setup()

{

  lcd.begin(16,2);
Serial.begin(9600);
pinMode(led, OUTPUT);
pinMode(Fan, OUTPUT);
pinMode(Light, OUTPUT);
pinMode(TV, OUTPUT);

  lcd.setCursor(0,0);
lcd.print("GSM Control Home");
lcd.setCursor(0,1); lcd.print("
Automaton "); delay(2000);
lcd.clear(); lcd.print("Circuit
Digest"); delay(1000);
lcd.setCursor(0,1);
```

```

lcd.print("System Ready");
Serial.println("AT+CNMI=2,2,0,
0,0"); delay(500);
Serial.println("AT+CMGF=1");
delay(1000); lcd.clear();
lcd.setCursor(0,0);
lcd.print("Fan Light TV ");
lcd.setCursor(0,1);
lcd.print("OFF OFF OFF ");

}

```

```

void loop()

```

```

{

  lcd.setCursor(0,0);
  lcd.print("Fan Light TV");
  if(temp==1)

  {

    check();
    temp=0;

    i=0;
    delay(1000);

  }
}

```

```

void serialEvent()

```

```

{

  while(Serial.available())

  {

    if(Serial.find("#A."))

```

```

    {

        digitalWrite(led, HIGH);
    delay(1000);
    digitalWrite(led, LOW);
    while (Serial.available())

        {

            char inChar=Serial.read();
            str[i++]=inChar;
            if(inChar=='*')

                {

                    temp=1;
                return;

                }

            }

        }

    }

}

void check()

{

    if(!(strcmp(str,"tv on",5)))

        {

            digitalWrite(TV, HIGH);

            lcd.setCursor(13,1);

            lcd.print("ON ");

            delay(200);

```

```

}

else if(!(strcmp(str,"tv off",6)))

{

    digitalWrite(TV, LOW);
lcd.setCursor(13,1);
lcd.print("OFF  ");
delay(200);

}

else if(!(strcmp(str,"fan on",5)))

{

    digitalWrite(Fan,
HIGH);
lcd.setCursor(0,1);
lcd.print("ON      ");
delay(200);

}

else if(!(strcmp(str,"fan off",7)))

{

    digitalWrite(Fan, LOW);
lcd.setCursor(0,1);
lcd.print("OFF  ");    delay(200);

```

```

}

else if(!(strcmp(str,"light on",8)))

{

    digitalWrite(Light, HIGH);
    lcd.setCursor(7,1);
    lcd.print("ON ");
    delay(200);

}

else if(!(strcmp(str,"light off",9)))

{

    digitalWrite(Light, LOW);
    lcd.setCursor(7,1);
    lcd.print("OFF ");
    delay(200);

}

else if(!(strcmp(str,"all on",6)))

{

    digitalWrite(Light, HIGH);
    digitalWrite(Fan, HIGH);
    digitalWrite(TV, HIGH);
    lcd.setCursor(0,1);
    lcd.print("ON ON ON ");
    delay(200);

```



```
}

else if(!(strcmp(str,"all off",7)))

{

    digitalWrite(Light, LOW);
digitalWrite(Fan, LOW);
digitalWrite(TV, LOW);
lcd.setCursor(0,1);
lcd.print("OFF OFF OFF ");
delay(200);

}

}
```

# CURRICULUM VITAE OF THE DESIGNER AND RESEARCHER



## **ABEREOLA, OLUWASEUN**

FLAT 14, FEDERAL POLYTECHNIC STAFF QUARTERS,  
ADO-EKITI, EKITI-STATE.

08160766923

[oluwaseun.abereola.0850@fuoye.edu.ng](mailto:oluwaseun.abereola.0850@fuoye.edu.ng)

[abereola.oluwaseun@gmail.com](mailto:abereola.oluwaseun@gmail.com)

---

### **Profile**

“A Very simple and approachable young man who enjoys connecting with people to floating ideas capable of meeting people’s needs, solving problems and taking up for them if needed”

---

### **Objective**

This curriculum vitae is targeted at giving an abridged version of who I am.

---

### **Educational Background and Experiences**

- B.ENG Degree programme in Mechatronics Engineering Currently in progress at Federal University Oye-Ekiti, Ekiti (FUOYE) [Graduation year: November 2017]
- West African Examination Council, 2011; Obtained at Ekiti State Government College, Ado-Ekiti
- God’s Grace Standard Nursery and Primary School, Aisegba-Ekiti.

---

### **Key Skills**

- Knowledgeable in CAE softwares
- Excellent problem solving skills
- Strong collaborative skills
- Microsoft Office literate
- Negotiation spirit
- Team raising and Leadership
- Public Speaking

---

### **Leadership Experience**

Sep 2005      God’s Grace Standard Nursery and Primary School,  
                  Aisegba- Ekiti  
&               **Senior Prefect Boy**

- Sep 2006 set**                      Job Description
- Representing the students and staffs of the school
- 
- Nov 2007**                      **God’s Grace Standard College; junior school,**  
**&**                                      **Pioneer Senior Prefect boy**  
**Oct 2008 set**                      Job Description
- Fostering a strong academic and moral relationships between staffs and students. .
- 
- 2010**                      **Ekiti State Government College, Ado-Ekiti**  
**&**                                      **Senior Prefect Boy,**  
**2011 set**                      Job Description
- Fostered a strong academic and moral relationships between staffs and students. .
- 
- 2010**                      **Ekiti State Government College, Ado-Ekiti**  
**President JET Club**  
Job Description
- Organising tutorials for club members.
  - Organising weekly technical discussion session.
  - Keeping a record of old and new club members.
- 
- 2009**                      **Ekiti State Government College, Ado-Ekiti**  
**President PRESS Clubs respectively.**  
Job Description
- Making request of weekly national dailies for club members.
  - Overseeing the editing of news.
  - Keeping a record of old and new club members.
- 
- 2009**                      **Ekiti State Government College, Ado-Ekiti**  
**Drama Coordinator, House Hold of Faith [College Chapel]**  
Job Description
- Organising weekly drama rehearsals for club members.
  - Reading and Selection of scripts.
  - Keeping a record of old and new club members.
- 
- 2010**                      **Ekiti State Government College, Ado-Ekiti**  
**Bible Studies Coordinator, House Hold of Faith [College Chapel].**  
Job Description
- Making monthly book requests of daily manna for club members.
  - Organising weekly bible studies and Sunday school’s preview discussion session.
  - Keeping a record of old and new club members.
- 
- 2010**                      **Ekiti State Government College, Ado-Ekiti**  
**General Secretary & Vice President [College Chapel].**  
Job Description
- Making monthly book requests of daily manna for club members.

- Organising weekly bible studies and Sunday school’s preview discussion session.
  - Keeping a record of old and new club members.
- 2013 to 2015 Chapel of Transformation [Formerly called FUYOYE Campus Chapel], FUYOYE Bible Studies and Sunday Schools Coordinator**
- Job Description
- Making monthly request of devotionals for club members.
  - Preparation of studies
  - Organising weekly previews.
  - Keeping a record of old and new members.
- Nov 2013 To Oct 2017 Mechatronics Engineering Department, FUYOYE Class Representative, 100 to 500 level** Ikole, Ekiti
- Job Description
- Maintaining of a steady stream of correspondence with the lecturers.
  - Ensuring there is an undelayed dissemination of information.
  - Rallying of effort towards beneficial causes.
- 2013/2014 Nigerian University Engineering Students Association,[ NUESA, FUYOYE] Administration Pioneer Assistant Secretary General Elected.**
- Job Description
- Assisting the General Secretary in the day to day administrative work.
- 2015/2017 National Association Of Mechatronics Engineering Students[NAMTES FUYOYE] & President Elected**
- 2016/2017 administrations** Job Description
- Overseeing the running of the association
- 2015/2016 Federation of Aisegba Students Union, FASU & Vice President Elected.**
- 2016/2017 administrations** Job Description
- Assisting the President in overseeing the running of the association.

## Interests

- Reading
- Planning and Organising
- Travelling
- Connecting with people
- Artificial Intelligence
- Automation

## Awards

- Bible Scholar of the year;  
From: Glorious Generations, COT
- Bible Studies and Sunday school  
Award Chapel of Transformation

[COT].

- Scholarship Award by Governor  
SEGUN oni, 2008

References are available on request.