



FEDERAL UNIVERSITY OYE-EKITI

November, 2017

A Thesis

Submitted by

ADELABU, WARRIZ OLAMIDE

EEE-12-0836

IN

PARTIAL FULFILLMENT OF THE REQUIREMENTS FOR THE DEGREE OF
BACHELOR OF ENGINEERING IN ELECTRONICS AND ELECTRONICS
ENGINEERING

Titled:

**DESIGN AND CONSTRUCTION OF A
VEHICLE TRACKING AND ACCIDENT ALERT
SYSTEM USING GPS AND GSM MODULE**

DEDICATION

I dedicate this project to victims of vehicle accidents especially those without on due rescue. Also to those who had lost their valuables to thefts and/or other abhorrent happenings in our society. You are indeed the motivation for this project.

DECLARATION OF ORIGINALITY

This project is all my own work and has not been copied in part or in whole from any other source except where duly acknowledged. As such, all use of previously published work (from books, journals, magazines, internet, etc. has been acknowledged within the main report to an entry in the References list.

I agree that an electronic copy or hardcopy of this report may be stored and used for the purposes of plagiarism prevention and detection.

I understand that cheating and plagiarism constitute a breach of University Regulations and will be dealt with accordingly.

Copyright

The copyright of this project and report belongs to Federal University, Oye-Ekiti.

Signed:

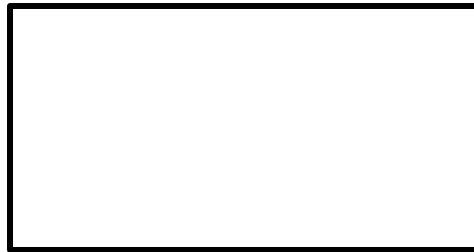

Date:

Office Stamp

CERTIFICATION

This is to certify that this project was carried out by **ADELABU WARRIZ OLAMIDE** with matric number **EEE/12/0836** of the Electrical and Electronics Engineering Department, Federal University Oye-Ekiti, Nigeria.

DR. ENGR. OLAITAN AKINSANMI
(PROJECT SUPERVISOR) SIGN & DATE

ENGR. G.K. IJEMARU
(DEPARTMENTAL PROJECT COORDINATOR) SIGN & DATE

DR. ENGR. OLAITAN AKINSANMI
(HEAD OF ELECTRICAL AND ELECTRONICS DEPARTMENT) SIGN & DATE

.....
EXTERNAL SUPERVISOR SIGN & DATE

ABSTRACT

This project is about the Design and Construction of a Vehicle Tracking and Accident Alert System (VTAA) using GPS and GSM Technology. It comprises of integration between GPS receiver, microcontroller and GSM module, and of course the push button for accident alert activation. The combination of all this technology will produce our VTAA system. The GPS module receive the coordinate of the point at which the system is located, controlled by the user using command interfaces through GSM module as a transmitter and receiver of data. This project is of two basic parts, the hardware and the software development. The hardware development includes the GPS, Push button and the microcontroller wiring connection, and its integration with GSM module. The software development includes the programming of the microcontroller (ATMEGA 8) with the source code, GSM message command, the NMEA protocol command and Google map API achievement. This system is controlled by users with centralized command interface through text.

1 TABLE OF CONTENTS

DEDICATION	i
DECLARATION OF ORIGINALITY	ii
CERTIFICATION	iii
ABSTRACT.....	iv
LIST OF TABLES	viii
LIST OF FIGURES	ix
ACRONYMS	x
ACKNOWLEDGEMENT	xi
CHAPTER ONE	1
1.0 INTRODUCTION TO A TRACKING SYSTEM	1
1.1 BACKGROUND OF THE PROJECT	3
1.2 STATEMENT OF THE PROBLEM	3
1.2.1 STEEPLE ANALYSIS	4
1.3 MOTIVATION	5
1.4 PROJECT AIM AND OBJECTIVES	5
1.5 SCOPE OF STUDY	5
1.6 ORGANIZATION OF REPORT	5
2 CHAPTER TWO	7
2.1 LITERATURE REVIEW	7
2.2 BACKGROUND.....	7
2.2.1 HISTORY OF GLOBAL POSITIONING SYSTEM (GPS)	7
2.2.2 GSM TECHNOLOGY	8
2.2.3 GSM MODEM.....	9
2.2.4 SUBSCRIBER IDENTITY MODULE (SIM).....	9
2.2.5 AIRBAG SAFETY	10
2.3 SURVEY OF THE RELATED WORK.....	10
2.4 DIFFERENT TECHNOLOGIES USED IN TRACKING SYSTEM.....	15
2.4.1 ACTIVE AND PASSIVE TRACKING	15
3 CHAPTER THREE	19
3.1 METHODOLOGY	19

3.2	MAJOR COMPONENTS USED:.....	19
3.2.1	MICROCONTROLLER	20
3.2.2	GPS (GLOBAL POSITIONING SYSTEM)	23
3.2.3	GSM.....	26
3.2.4	POWER SUPPLY.....	29
3.3	PROCEDURES OF DESIGN AND CONSTRUCTION	30
3.4	WORKING PRINCIPLE OF THE VEHICLE TRACKING AND ACCIDENT ALERT 32	
3.5	SYSTEM ARCHITECTURE.....	32
4	CHAPTER FOUR	36
4.1	TESTING, ANALYSIS OF RESULTS AND DISCUSSIONS	36
4.1.1	HARDWARE ASSEMBLING AND TESTING:	36
4.2	RESULTS.....	36
4.3	PERFORMANCE EVALUATION	38
4.3.1	PERFORMNCE ANALYSIS USING DIFFERENT SIM	39
4.3.2	BENEFITS AND APPLICATION OF VAAT SYSTEM	40
4.4	PROJECT MANAGEMENT	41
4.5	RISK MANAGEMENT.....	43
4.5.1	HACKERS	43
4.5.2	SURGE AND THUNDER EFFECT	43
4.6	ETHICAL ISSUES	43
4.6.1	PRIVACY	43
4.6.2	DATA OWNERSHIP	44
5	CHAPTER FIVE.....	45
5.1	CONCLUSIONS	45
5.2	LIMITATIONS	45
5.3	FUTURE WORK.....	46
5.4	DESIGN CONSTRAINTS.....	46
5.5	CONTRIBUTION TO KNOWLEDGE.....	46
5.6	CRITICAL APPRAISAL.....	47
	REFERENCES	48

LIST OF TABLES

<i>Table 1: Comparism of Existing Project.....</i>	17
<i>Table 4.1: SIM in GSM module fixed MTN.....</i>	39
<i>Table 4.2 SIM in GSM module fixed Airtel</i>	39
<i>Table 4.3: SIM in GSM module fixed GLO.....</i>	39
<i>Table 4.4: SIM in GSM module fixed 9MOBILE.....</i>	39
<i>Table 5: Gang Chat illustrating project activities and duration</i>	42

LIST OF FIGURES

<i>Fig 2.1</i> airbag	10
<i>Fig. 2.2:</i> Telit GM862 module used for a tracking system.....	14
<i>Fig.3.1:</i> Block Diagram of Vehicle Tracking System	19
<i>Fig. 3.2</i> pin diagram of microcontroller ATMEGA 8 (Atmel, 2013)	21
<i>Fig. 3.4</i> Block and Pictorial Diagram of a Global Positioning System (Paralax, 2015)	24
<i>Fig 3.5</i> SIM800 (SIMCOM, 2015)	26
<i>Fig. 3.6:</i> SIM800 functional diagram (SIMCOM, 2015).....	28
<i>Fig 3.6.1:</i> SIM800 pin out diagram.....	28
<i>Fig 3.7</i> Power supply.....	29
<i>Fig 3.8</i> Pictorial representation of Power supply.....	29
<i>Fig. 3.9:</i> complete Circuit Diagram of VAAT system.....	32
<i>Fig. 3.10:</i> System architecture	34
<i>Fig 4.1:</i> view of project during testing and evaluation.....	36
<i>Fig 4.2:</i> view of communication between user and VTAA system via text message.....	37
<i>Fig 4.3:</i> View of location on website through Google map.....	38

ACRONYMS

GPS	Global Positioning System
GPRS	General Packet Radio Service
SIM	Subscriber Identification Module
HTTP	Hypertext Transfer Protocol
GSM	Global System for Mobile communications
EGSM	Extended Global System for Mobile communications
DCS	Digital Cellular Service
PCS	Personal Communications Service
TTFB	Time-To-First-Fix
CS	Communication Service
PHP	Hypertext Preprocessor
XML	Hypertext Mark-up Language
WAMP	Windows Apache MySQL PHP
GGSN	Gateway GPRS Support Node
PCB	Power Circuit Board
AT	Attention commands
MISO	Master in Slave Out
MOSI	Master Out Slave In
SCK	Clock Signal from master to slave
GND	Ground Signal
GPIO	General Purpose Input/output
MCU	Microcontroller Unit
RISC	Reduced Instruction Set Computer
MIPS	Million Instructions per Second
ALU	Arithmetic Logic Unit
EEPROM	Electrically Erasable Programmable Memory
SRAM	Static Random Access Memory
I/O	Input/output

ACKNOWLEDGEMENT

I am deeply grateful to the members of Staff (Academic and nonacademic) of the Electrical and Electronics Engineering Department, Federal University Oye-Ekiti, especially my amicable project supervisor, Dr Engr Olaitan Akinsanmi, for giving me the opportunity to work on this project, and for guidance and cooperation; and also my family, the Adelabu family, a family like no other, thank you for believing in me, your love and encouragement kept me going.

To my friends and colleagues starting with Raheem Waliyullah, Ubani Bright, Joshua, Miracle, Toba and the rest not mentioned, I couldn't have completed this project without your invaluable contributions. I appreciate you all.

Lastly to God almighty, you have been my Alfa and Omega, I bless you for making this is a success.

CHAPTER ONE

1.0 Introduction to a Tracking System

The vehicle tracking system is a total security and fleet management solution. It is the technology used to determine the location of a vehicle using different methods like GPS and other navigation system operating via satellite and ground based stations. Modern vehicle tracking system uses GPS technology to monitor and locate our vehicle anywhere on earth, but sometimes different types of automatic vehicle location technology are also used. The vehicle tracking system is fitted inside the car that provides location and the data can even be stored and downloaded to a computer which can be used for analysis in future. This system is an essential device for tracking car any time the owner wants to monitor it and today it is extremely popular among people having expensive cars, used as theft prevention and recovery of the stolen car. The data collected can be viewed via SMS [receiving the position coordinate} or on electronic maps via internet and software.

However, the high demand of vehicles has also increased the traffic hazards and the road accidents. Life of the people is under high risk. This is because of the lack of best emergency facilities available in our country. An automatic alert system for vehicle accidents is introduced in this project. This system which can detect accidents in significantly less time and sends the basic information to a defined contact (say next of kin and emergency dispatch Centre) within a few seconds covering geographical coordinates, the time and angle in which a vehicle accident had occurred. This alert message is sent to the central emergency dispatch server in a short time so that the emergency dispatch server will inform the ambulances which are near to that location, which will help in saving the valuable lives.

When the accident occurs the alert message is sent automatically to the central emergency dispatch server. The message is sent through the GSM module and the location of the accident is detected with the help of the GPS module. The accident can be detected precisely with the help of vibration sensor. This application provides the optimum solution to poor emergency facilities provided to the road accidents in the most feasible way.

The project, "Vehicle Tracking and Accident Alert System using GPS and GSM Technology" is designed and developed to accommodate the needs of today's vehicle fleet company to keep track on their fleets. It is a very useful and versatile device, and in fact it is able to be used by

anybody with the need to keep track on their valuable goods, increase safety and not just by the vehicle fleets company. This chapter will be covering the general background of this project, its concept, objectives, scope and the problem statement.

A GPS-GPRS based tracking system gives all the specifications about the location of a vehicle. The system utilizes geographic position and time information from the Global Positioning Satellites in order to track the movement of the vehicle. Google Maps is used for mapping the location. The GSM modem fetches the GPS location and sends it to the server using GPRS. The device includes modern hardware and software components that help to track and locate automobiles both online and offline. A tracking system comprises mainly three parts- vehicle unit, fixed based station and database with software system (ASHUTOSH et al, 2014)

The integration of GPS and GSM was first established using SMS as a method of transmitting GPS coordinates. The inclusion of GPRS technology to transmit location coordinates to a remote server facilitates the tracking of object remotely using any computer connected to the web.

A GPS tracking unit is a device that uses the Global Positioning System to determine the precise location of a vehicle or other asset to which it is attached. A GPS receiver is operated by a user on Earth, it measures the time taken by radio signals to travel from four or more satellites to its location, it then calculates its distance from each satellite, and from this calculation it determines the longitude, latitude, and altitude of that position. By following triangulation or trilateration methods the tracking system determines the location of the vehicle easily and accurately (ASHUTOSH et al, 2014). Trilateration is a method of determining the relative positions of objects using the geometry of triangles. To "triangulate," a GPS receiver accurately measures the time taken by the satellite to make its brief journey to Earth (less than a tenth of a second) and hence measures its distance from the satellite using the travel time of the radio signal. To determine the distance between it and the satellite, the measured time is multiplied by the speed of a radio wave that is 300,000 km (186,000 miles) per second (ASHUTOSH et al, 2014). The coordinates of latitude and longitude can be sent to the user on request via SMS, or it may be transmitted and stored in the database, using a cellular or satellite modem that is the GSM modem embedded in the unit. This enables the user to display the asset's location on the Google map either in real time or later whenever the user wants the data for further analysis.

1.1 Background of the Project

A vehicle tracking and Accident Alert system consists of an electronic device installed on a vehicle so that it could be tracked by its owner or a third-party for its position. Most of today's vehicle tracking system uses Global Positioning System (GPS) to get an accurate reading of the vehicle position. Communication components such as cellular (GSM) and satellite transmitter will be combined to transmit the vehicle's position to remote user. Vehicle's information can be viewed by using software on a computer. Vehicle tracking systems are commonly used by fleet operators for fleet management functions such as routing, dispatch, on-board information and security.

Other applications include monitoring driving behavior, such as an employer of an employee, or a parent with a teen driver. Vehicle tracking systems are also popular in consumer vehicles as a theft prevention and retrieval device. Police can simply follow the signal emitted by the tracking system and locate the stolen vehicle. When used as a security system, a Vehicle Tracking System may serve as either an addition to or replacement for a traditional Car alarm. The existence of vehicle tracking device then can be used to reduce the insurance cost, because the loss-risk of the vehicle drops significantly.

Vehicle tracking is also useful in many other applications such as Asset Tracking scenarios where companies needing to track valuable assets for insurance or other monitoring purposes can now plot the real-time asset location on a map and closely monitor movement and operating status. Meanwhile, in field sales mobile, the situation of sales professionals can easily access real-time locations. For example, in unfamiliar areas, they can locate themselves as well as customers and prospects, get driving directions and add nearby last-minute appointments to itineraries. Benefits include increased productivity, reduced driving time and increased time spent with customers and prospects.

1.2 Statement of the Problem

The global issue related to a constantly increasing crime rate needs to be urgently addressed by both developed and developing countries. In Nigeria, 2,000 cases of car theft in average are reported each year in [Nairaland.com, 2011], and the number is still increasing. If not recovered soon, stolen vehicles are generally sold, revamped or even burned if the resale price is considered to be too low. Once a vehicle is stolen, it becomes hard to locate it and track it, which considerably decreases the chances of recovering it. In this work, we propose the design and

implementation of a car tracking anti-theft system that will protect, secure vehicles. More so, the bad culture of private and commercial drivers accompanied with the poor roads and road trafficking in the country has in time increases the rate of casualties on the road so rapidly, 35% of death rate in Nigeria was caused by Vehicle accident and road casualties in the year 2016. This project is focused mainly to increase the chances of survival for the victims of these causalities as introduced earlier.

1.2.1 STEEPLE Analysis

STEEPLE Analysis is "a model for strategic decision that takes into consideration seven main macro-environmental factors in the activity of analysis, assessment and forecast of the impact of the decision to be made" (WEBERIENCE LLC, 2017). STEEPLE stands for societal, technical, environmental, ethical, political, legal and economic factors. In this project, I adopted STEEPLE model to analyze and assess the potential impact of my solution. The following table identifies the seven macro-environmental factors related to this project which include societal, technical, environmental, ethical, political, legal and economic factors.

Societal: Poverty, population growth and urban migration are considered among the main drivers of crime. In this context, rising thefts means rising demand and rising need for anti-theft sand accident alert solution.

Technological: The emergence of microcontrollers and single board Nano-computers in the past few years has enabled the design of efficient embedded system.

Ecological: Tracking, tracing and monitoring a vehicle help in analyzing drivers behavior. In fact, analyzing driving behavior makes it possible to lessen risks of accidents and decrease fuel consumption, thus, CO2 emissions.

Ethical: Ethics issues of liberty and privacy is a main concern in geo-location systems.

Political: In April 2016, the Minister of Transportation, Rt. Hon. Rotimi Amaechi made more efforts in dealing with criminal phenomena that threatens the security and serenity of citizens valuable in transport networks (Nairaland.com, 2016).

Legal: National Union of Road Transport Workers (NURTW) does not address in a direct and clear way their concern regarding the use of geo-location systems and I argue that the implementation of this will be of a huge benefit to the security and protection of their members and clients.

Economic: Nowadays, many companies tend to use fleet management solutions to lessen their transportation costs. Furthermore, insurance companies in Nigeria (Nairaland.com, 2014) start embracing and mandating anti-theft solutions as part of the conditions for insurance.

1.3 Motivation

The alarming rate of vehicle theft and road accidents was the major motivation for this project. I had been inspired to develop a solution since I was once a victim of a road accident. I believe this system if well implemented will help increase the chance of recovering stolen vehicles in essence increasing vehicle security. It also will increase the survival chance of accident victims through the accident alert system.

1.4 Project aim and objectives

The aim of this project is to Design and Construct a Vehicle Tracking and Accident Alert System using GPS and GSM Technology.

Objectives of this project are:

- 1) To study and investigate the basic operation of the GPS module.
- 2) To design the GPS/GSM and Push button based on the system.
- 3) To ensure design perfection through simulation and breadboard layout.
- 4) To implement the designed system on a hardware prototype.
- 5) To analyze the efficiency of the developed system.

1.5 Scope of Study

In this project, software and hardware developments were the major scopes put into consideration. The power supply unit (AC to DC) and wiring of the modules with the microcontroller defines hardware development. The software session on the other hand encompasses writing of source code to the microcontroller and generation of Google API to view position on Google map. The appropriate integration of this sessions cover the design and construction of the VTAA (Vehicle Tracking and Accident Alert) system

1.6 Organization of report

Chapter one presents the introductory part of this project work. The rest of this work is organized as follows: Chapter two reviews the current related literature to the work, while Chapter three describes the methodological approaches and design specifications. Chapter four presents

simulation results and analysis, followed by Conclusion, Recommendations, Limitations, and Future work directions in Chapter five.

2 CHAPTER TWO

2.1 LITERATURE REVIEW

2.2 BACKGROUND

In this chapter, the articles of the GPS history, GSM communication technology, brief on the components theory and a description couple of similar projects are covered.

2.2.1 HISTORY OF GLOBAL POSITIONING SYSTEM (GPS)

The GPS System was created and realized by the American Department of Defense (DOD) and was originally based on and run with 24 satellites (21 satellites being required and 3 satellites as replacement). Nowadays, about 30 active satellites orbit the earth in a distance of 20200 km. GPS satellites transmit signals which enable the exact location of a GPS receiver, if it is positioned on the surface of the earth, in the earth atmosphere or in a low orbit. GPS is being used in aviation, nautical navigation and for the orientation ashore. Further it is used in land surveying and other applications where the determination of the exact position is required. The GPS signal can be used without a fee by any person in possession of a GP (wikipedia, 2016) receiver (U.S. Department of State, 2013).

In 1973, Decision has been made to develop a satellite navigation system based on the systems TRANSIT, TIMATION und 621B of the U.S. Air Force and the U.S. Navy. Four years later, First receiver tests are performed even before the first satellites are stationed in the orbit. Transmitters are installed on the earth's surface called **Pseudolites** (Pseudo satellites). By 1985, a total of 11 Block I satellites are launched into the orbit. Decision has been made to expand the GPS system. Thereupon the resources are considerably shortened and the program is restructured. At first only 18 satellites should be operated. 1988 the number of satellites is again raised to 24, as the functionality is not satisfying with only 18 satellites.

Launching of the first Block I satellite carrying sensors to detect atomic explosions, this satellite is meant to control the abidance of the agreement of 1963 between the USA and the Soviet Union to refrain from any nuclear tests on the earth, submarine or in space. When a civilian airplane of the Korean Airline (Flight 007) was shot down after it had gone lost over Soviet territory, it was decided to allow the civilian use of the GPS system. In 1986, the accident of the space shuttle "Challenger" means a drawback for the GPS program, as the space shuttles were

supposed to transport Block II GPS satellites to their orbit. Finally the operators of the program revert to the Delta rockets intended for the transportation in the first place.

In 1989, the first Block II satellite was installed and activated temporal deactivation of the selective availability (SA) during the Gulf war. In this period civil receivers should be used as not enough military receivers were available. On July 01, 1991 SA is activated again. The Initial Operational Capability (IOC) is announced in 1993. In the same year it is also definitely decided to authorize the world wide civilian use free of charge.

The last Block II satellite completes the satellite constellation in 1994. Full Operational Capability (FOC) is announced the following year. In 2000, was the final deactivation of the 100m to 20m? (Global System for Mobile Communication, 2016)

2.2.2 GSM TECHNOLOGY

GSM is a cellular network, which means that mobile phones connect to it by searching for cells in the immediate vicinity. GSM networks operate in four different frequency ranges. Most GSM networks operate in the 900 MHz or 1800 MHz bands. Some countries in the Americas (including Canada and the United States) use the 850 MHz and 1900 MHz bands because the 900 and 1800 MHz frequency bands were already allocated (Al-Hindawi, 2012).

GSM has used a variety of voice codecs to squeeze 3.1 kHz audio into between 5.6 and 13 Kbit/s. Originally, two codecs, named after the types of data channel they were allocated, were used, called Half Rate (5.6 Kbit/s) and Full Rate (13 Kbit/s). These used a system based upon linear predictive coding (LPC). In addition to being efficient with bitrates, these codecs also made it easier to identify more important parts of the audio, allowing the air interface layer to prioritize and better protect these parts of the signal. GSM was further enhanced in 1997 with the Enhanced Full Rate (EFR) codec, a 12.2 Kbit/s codec that uses a full rate channel. Finally, with the development of UMTS, EFR was refactored into a variable-rate codec called AMRN narrow band, which is high quality and robust against interference when used on full rate channels, and less robust but still relatively high quality when used in good radio conditions on half-rate channels.

There are five different cell sizes in a GSM network—macro, micro, Pico, femto and umbrella cells. The coverage area of each cell varies according to the implementation environment. Macro cells can be regarded as cells where the base station antenna is installed on a mast or a building

above average roof top level. Micro cells are cells whose antenna height is under average roof top level; they are typically used in urban areas. Picocells are small cells whose coverage diameter is a few dozen meters; they are mainly used indoors. Femtocells are cells designed for use in residential or small business environments and connect to the service provider's network via a broadband internet connection. Umbrella cells are used to cover shadowed regions of smaller cells and fill in gaps in coverage between those cells (wikipedia, 2016).

The modulation used in GSM is Gaussian minimum-shift keying (GMSK), a kind of continuous-phase frequency shift keying. In GMSK, the signal to be modulated onto the carrier is first smoothed with a Gaussian low-pass filter prior to being fed to a frequency modulator, which greatly reduces the interference to neighboring channels (adjacent channel interference).

2.2.3 GSM MODEM

A GSM modem is a wireless modem that works with a GSM wireless network. A wireless modem behaves like a dial-up modem. The main difference between them is that a dial-up modem sends and receives data through a fixed telephone line while a wireless modem sends and receives data through radio waves.

A GSM modem can be an external device or a PC Card / PCMCIA Card. Typically, an external GSM modem is connected to a computer through a serial cable or a USB cable. A GSM modem in the form of a PC Card / PCMCIA Card is designed for use with a laptop computer. It should be inserted into one of the PC Card / PCMCIA Card slots of a laptop computer. Like a GSM mobile phone, a GSM modem requires a SIM card from a wireless carrier in order to operate (wikipedia, 2016).

2.2.4 SUBSCRIBER IDENTITY MODULE (SIM)

One of the key features of GSM is the Subscriber Identity Module (SIM), commonly known as a SIM card. The SIM is a detachable smart card containing the user's subscription information and phone book. This allows the user to retain his or her information after switching handsets. Alternatively, the user can also change operators while retaining the handset simply by changing the SIM. Some operators will block this by allowing the phone to use only a single SIM, or only a SIM issued by them; this practice is known as SIM locking, and is illegal in some countries.

2.2.5 AIRBAG SAFETY

An airbag is a type of vehicle safety device and is an occupant restraint system. The airbag module is designed to inflate extremely rapidly then quickly deflate during a collision or impact with a surface or a rapid sudden deceleration. It consists of the airbag cushion, a flexible fabric bag, inflation module and impact sensor. The purpose of the airbag is to provide the occupants a soft cushioning and restraint during a crash event to prevent any impact or impact caused injuries between the flailing occupant and the interior of vehicle. The airbag provides an energy absorbing surface between the vehicles occupants and a steering wheel.

In VTAA system, the airbag when busted pushes the pushbutton which sends a signal to the microcontroller that there had been an accident. Message is then sent to the defined number showing that an accident had occurred in a particular location.



Fig 2.1: airbag

2.3 SURVEY OF THE RELATED WORK

Benjamin et al. (2013), based tracking system for detecting vehicles under challenging conditions such as increasing congestion on freeways and problems associated with existing detectors. In their system, instead of tracking entire vehicles, vehicle features were tracked to make the system robust to partial occlusion. The system was fully functional under changing lighting conditions because the most salient features at the given moment were tracked. After the features exit the tracking region, they were grouped into discrete vehicles using a common motion constraint. The groups represented individual vehicle trajectories which can be used to measure traditional traffic parameters as well as new metrics suitable for improved automated surveillance. Their paper describes the issues associated with feature based tracking, presents the real-time implementation of a prototype system, and the performance of the system on a large data set.

Ramya et al. (2012), developed the system named as "Embedded Controller for Vehicle In-Front Obstacle Detection and Cabin Safety Alert System". According to their research paper, they had developed a system which had provided good safety and security while travelling. Their project was basically to design an embedded system for vehicle cabin safety and security by modifying and integrating the existing modules. This monitored the level of the toxic gases such as CO, LPG and alcohol inside the vehicle and provided alert information in the form of alarm during the critical situations. And also sent SMS to the authorized person through the GSM. An IR Sensor was used to detect the static obstacle in front of the vehicle and the vehicle got stopped if any obstacle was detected. This may avoid accidents due to collision of vehicles with any static obstacles.

Alexe and Ezhilarasie (2011), developed the vehicle tracking system named as "Cloud Computing Based Vehicle Tracking Information Systems" which was implemented using centralized web service and cloud computing. The proposed technology was based on GPS technology, GSM and cloud computing infrastructure. The vehicles were fitted with specialized embedded device, GPS device and GSM enabled device. The embedded device was fitted with "sensors". The sensors involve:

- [1] To identify the fuel level/status.
- [2] Alcohol sensor – status of the driver.
- [3] To identify current name of the location.
- [4] To find distance covered.
- [5] To predict arrival time.

This data were transferred to cloud server through GSM enabled device. The GPS device was used to track the vehicle locations. All the data's were stored in centralized server which was maintained in cloud. Each licensed vehicle owner could access the cloud using web portal. From the web portal the user could retrieve all the real time data. Proposed system may allow for the stability, equilibrium, efficient resource use and sustainability of a tracking system.

Benjamin et al. (2013), designed the system named as "Vehicle Tracking and Locking System Based on GSM and GPS" for the safety of vehicles to avoid a theft of vehicles. Vehicle tracking and locking system was installed in the vehicle, to track the place and locking engine motor. The place of the vehicle was identified using Global Positioning system (GPS) and Global system mobile communication (GSM). These systems was constantly watched a moving Vehicle and

reported the status on demand. When the theft was identified, the responsible person sent SMS to the microcontroller, then microcontroller issued the control signals to stop the engine motor. Authorized person needed to send the password to controller to restart the vehicle and open the door. Their system was more secured, reliable and low cost.

In (Asaad et al. 2012), the hardware and software of the GPS and GSM network were developed. The proposed GPS/GSM based System has the two parts, first is a mobile unit and another is controlling station. The system processes, interfaces, connections, data transmission and reception of data among the mobile unit and control stations are working successfully. These results are compatible with GPS technologies.

In (Kunal et al. 2016), a vehicle tracking system is an electronic device, installed in a vehicle to enable the owner or a third party to track the vehicle's place. This paper proposed to design a vehicle tracking system that works using GPS and GSM technology. This system built based on embedded system, used for tracking and positioning of any vehicle by using Global Positioning System (GPS) and Global system for mobile communication (GSM). This design will continuously watch a moving Vehicle and report the status of the Vehicle on demand.

In (Henster et al. 2012), special issue of IJCCT, Face Detection System used to detect the face of the driver, and compare with the predefined face. The car owner is sleeping during the night time and someone theft the car. Then Face Detection System obtains images by one tiny web camera, which is hidden easily in somewhere in the car. Face Detection System compared the obtained images with the stored images. If the images don't match, then the information sends to the owner through MMS. The owners get the images of the thief in mobile phone and trace the place through GPS. The place of the car and its speed displayed to the owner through SMS. The owner can recognize the thief images as well as the place of the car and can easily find out the hijackers image. This system applied in our day-to-day life.

In (Ramya et al. 2012), this system provided vehicle cabin safety, security based on embedded system by modifying the existing modules. This method monitors the level of the toxic gases such as CO, LPG and alcohol within the vehicle provided alert information as alarm during the dangerous situations. The SMS sends to the authorized person through the GSM. In this method, the IR Sensor used to detect the static obstacle in front of the vehicle and the vehicle stopped if any obstacle detected. This is avoiding accidents due to collision of vehicles with any static obstacles.

Song et al. (2005), designed and built on a real-time visual tracking system for vehicle safety applications. In this paper built a novel feature-based vehicle-tracking algorithm, automatically detect and track several moving objects, like cars and motorcycles, ahead of the tracking vehicle. Joint with the concept of focus of expansion (FOE) and view analysis, the built system can segment features of moving objects from moving background and offer a collision word of warning on real-time. The proposed algorithm using a CMOS image sensor and NMOS embedded processor architecture. The constructed stand-alone visual tracking system validated in real road tests. The results provided information of collision warning in urban artery with speed about 60 km/hour both at night and day times.

In (Peijiang et al. 2008) and (Alexe et al. 2011), the remote monitoring system based on SMS and GSM was implemented. Based on the total design of the system, the hardware and software designed. In this paper, the GSM network is a medium for transmitting the remote signal. This includes two parts that are the monitoring center and the remote monitoring station. The monitoring centers consist of a computer and communication module of GSM. The software-monitoring center and the remote monitoring station implemented by using VB. The result of this demonstration shows that the system can watch and control the remote communication between the monitoring center and the remote monitoring station.

Alexe et al. (2011), proposed tracking system based on cloud computing infrastructure. The sensors are used to monitor the fuel level, driver conditions, and speed of the vehicle. All the data transferred to cloud server-using GSM enabled device. All the vehicles equipped with GPS antenna to locate the place. To avoid the drunk and drive, the alcohol sensor installed to monitor the driver status. The proposed technology significantly avoids the accident in highways. Application. According to their research paper, they had built on a produced VTS (The Aram Locator) offering a system-on-chip (SOC) replacement of the current microcontroller-based implementation. The proposed SOC was built on a field programmable gate array (FPGA) promising a cheaper design, a more cohesive architecture, a faster processing time and an enhanced system interaction. Different designs, and their hardware implementations, were proposed with different levels of integration. Performance analysis and evaluation of the investigated designs were included.

There have been many other projects on the internet that uses the same concepts applied on this project. But most of the projects use a combined GPS and GSM module, as it is easier to operate. Here is the example of the project found on the internet:

1. GPS/GSM tracking system using Telit GM862 module.

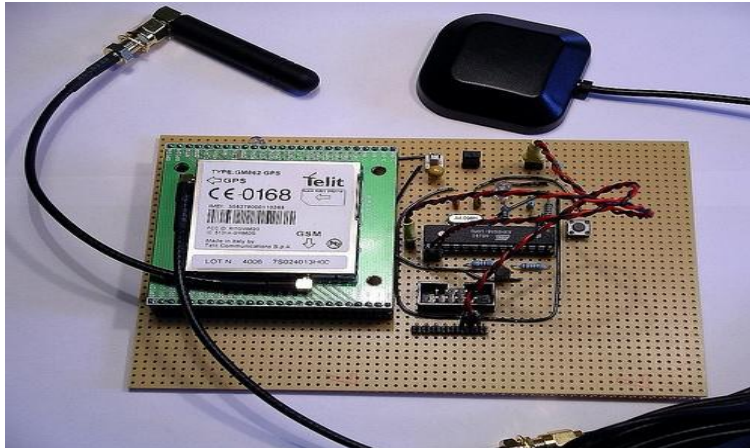

Fig. 2.2: Telit GM862 module used for a tracking system

The inventor is unknown but his goal is to build a mobile tracker. There are many different use cases we can think of but one of the obvious is a device that is able to report where it is. This device can be put in the car and it could trigger an alarm, if the car got stolen. It actually could tell you where it is.

There are already mobile tracking devices out there, but they seemed to be too expensive and too closed for our needs. Another option is one of this new Nokia N95 which has built-in GPS. They are really nice, but about N140, 000, which is not a bargain.

The idea was to combine a microcontroller with a GSM and a GPS module. The Telit GM862 is used in this project, which is a GSM module with a built in GPS receiver. This module offers quad band GSM, has SiRF III GPS built in. This project will also be able to become a mobile phone if equipped with a speaker and a microphone because it also offers data, voice, SMS and fax communication.

The approaches employed in the development of each project sighted above are put together in the accomplishment of this project. Furthermore, new technology has integrated the GPS and the GSM technology making the project more modified and less expensive. Real time tracking system can with this development be well affordable. More importantly, a shock sensor is as well attached majorly for the detection of accident.

If lives can't be made yet technologically, I'm convinced that nothing is more important than saving it, this project will greatly influence the mortality rate positively and put many lives back on track.

2.4 Different Technologies used in Tracking System

2.4.1 Active and passive tracking

Several types of vehicle tracking devices exist. Typically they are classified as "passive" and "active". "Passive" devices store GPS location, speed, heading and sometimes a trigger event such as key on or off, door open or closed. Once the vehicle returns to a predetermined point, the device is removed and the data downloaded to a computer for evaluation. Passive systems include auto download type that transfer data via wireless download. "Active" devices also collect the same information but usually transmit the data in real-time via cellular or satellite networks to a computer or data center for evaluation. As opposed to the passive technology, Active tracking technology is employed in this project.

Passive trackers do not monitor movement in real-time. When using a passive GPS tracker, you will not be able to follow every last move that a tracked person or object makes. Instead, information that is stored inside of a passive tracker must be downloaded to a computer. Once tracking details have been downloaded, it is then possible to view tracking details.

After we have gathered all of the information we need from a passive tracker, we can place the tracker back on the same (or different) vehicle. Aside from the fact that a passive tracking device is entirely reliable, the main reason people choose passive trackers is that these devices are less expensive than active trackers. Most passive GPS tracking devices are not attached to a monthly fee, which makes these trackers affordable.

In contrast to passive devices, active GPS trackers will allow one to view tracking data in real-time. As soon as we place an active tracker on a vehicle, we will be able to view location, stop duration, speed, and other tracking details from the comfort of your home or office. Active GPS trackers are ideal when it comes to monitoring vehicle that need to be tracked at regular time interval.

While active tracking devices are more expensive than passive devices (most come with monthly fees), this expensive is usually justified. An active GPS tracker that comes with a reliable interface (and excellent tracking software), and you will be able to track anything or anyone quickly and efficiently.

When most people picture a GPS tracking device, they are picture a real-time tracker. These trackers can be attached to any object while a person monitors all activity from a home computer. For example, if you were to place a real-time tracker on a vehicle, you could then

watch as the vehicle makes stops, takes alternate routes, and sits idling – all in real-time. GPS trackers that work on a real-time basis are usually considered "active" trackers, while those that do not include real-time tracking are considered "passive" trackers.

There are many advantages associated with a real time tracker. The most important advantage is that the GPS locator is convenience. Rather than waiting to download data to a computer (as is the case with most passive trackers), a tracker that works in real-time does not require any waiting. Since real-time trackers come with software that allows a user to track an object in real-time, watching any object's progress is simply a matter of sitting at a computer.

Table 1: Comparism of Existing Project

SYSTEM NAME	AUTHOR	YEAR	FUNCTIONALITY
A Real Time Computer Vision System for Vehicle Tracking and Traffic surveillance	Benjamin Coifman	2003	This was the feature based tracking system for detecting vehicles under challenging conditions such as increasing congestion on freeways.
GPS-based Vehicle Tracking System-on-Chip	Adnan I. Yaqzan, Issam W. Damaj, and Rached N. Zantout	2008	This was a real-time, fast and reliable data processing application.
Cloud Computing Based Vehicle Tracking Information Systems.	Albert Alexe and R.Ezhilarasie	2011	This tracking system was implemented using centralized web service and cloud computing. The proposed technology was based on GPS technology, GSM and cloud computing infrastructure. The vehicles were fitted with specialized embedded device, GPS device and GSM enabled device.
Embedded Controller for Vehicle In-Front Obstacle Detection and Cabin Safety Alert System	V.Ramya, B.Palaniappan and K.Karthick	2012	This system had provided good safety and security while travelling. This monitored the level of the toxic gases such as CO, LPG and alcohol inside

			the vehicle and provided alert information in the form of alarm during the critical situations.
Tracking and Locking System Based on GSM and GPS	R. Ramani, S. Valarmathy, Dr. N. Suthanthira Vanitha, S. Selvaraju, M. Thirupathi and R.Thangam	2013	This system was developed for the safety of vehicles to avoid a theft of vehicle. In this, vehicle tracking and locking system was installed in the vehicle, to track the place and locking engine motor .The place was identified by using GPS and GSM
Real Time Vehicle Tracking System using GSM and GPS Technology-An Anti-Theft Tracking System	Kunal Maurya, Mandeep Singh and Neelu Jain	2014	This was an electronic device which was installed in a vehicle to enable the owner or a third party to track the vehicle's location.

3 Chapter Three

3.1 METHODOLOGY

In this proposed work, a novel method of vehicle tracking and accident alarm system used to track the theft vehicle by using GPS and GSM technology. This system puts into sleeping mode while the vehicle handled by the owner or authorized person otherwise goes to active mode, the mode of operation changed by in person or remotely. If any accident occur, then the push button attached to the air bag senses a signals and sends and SMS to the microcontroller. The controller issues the message about the accident of the vehicle to the car owner or authorized person.

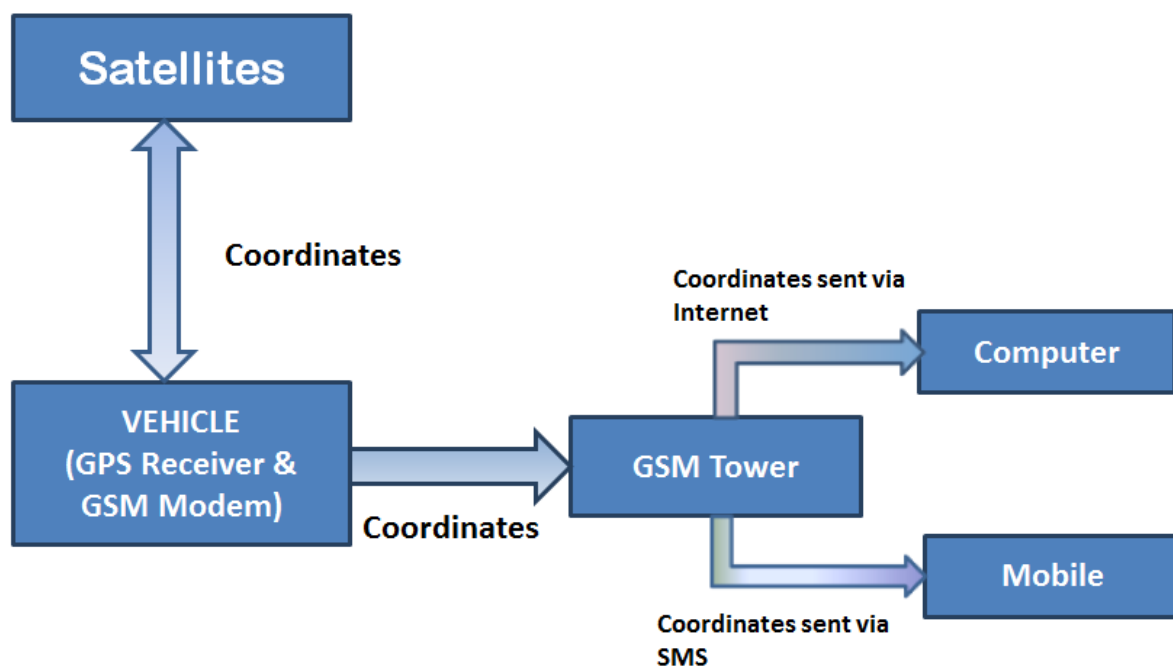

Fig.3.1: Block Diagram of Vehicle Tracking System

3.2 MAJOR COMPONENTS USED:

- I. ATMEGA 8 AVR
- II. Parallax GPS Receiver Module
- III. SIM 800
- IV. PUSH BUTTON
- V. POWER SUPPLY

To ascertain perfection in the design of the project, simulation was carried out using Proteus software. It was quite a bit of challenge to run as the library for the GSM and GPS module are not readily available on the software. This challenge was mitigated by downloading and installing the GPS and GSM module library through the software. I was finally able to conduct the simulation as shown in Figure3.2. The virtual GPS readings (point coordinates) were observed and the ideal behavior of the system was confirmed before running connection test on breadboard then permanently on flux board.

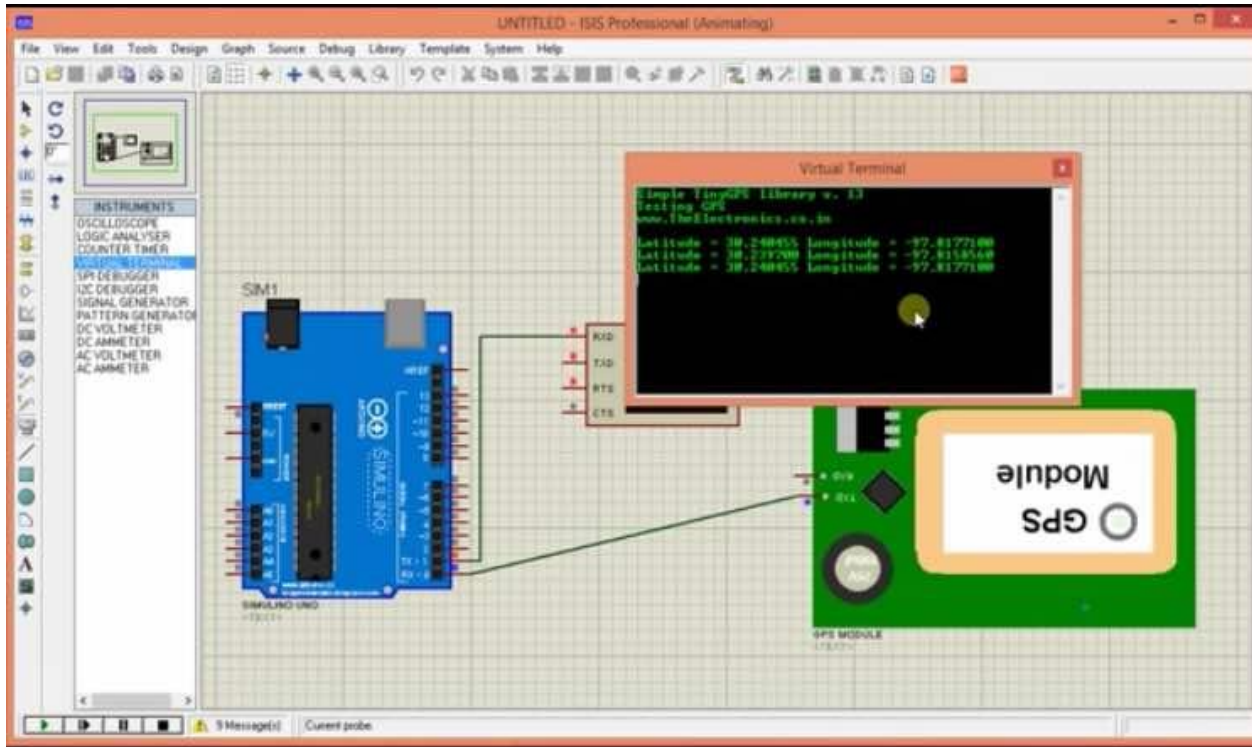

Fig.3.2: Simulation of a VTAA system using Proteus software

3.2.1 MICROCONTROLLER

The microcontroller used in this work is Atmel®AVR® ATmega8 and it is a low-power CMOS 8-bit microcontroller based on the AVR RISC architecture. By executing powerful instructions in a single clock cycle, the ATmega8 achieves throughputs approaching 1MIPS per MHz, allowing the system designed to optimize power consumption versus processing speed.

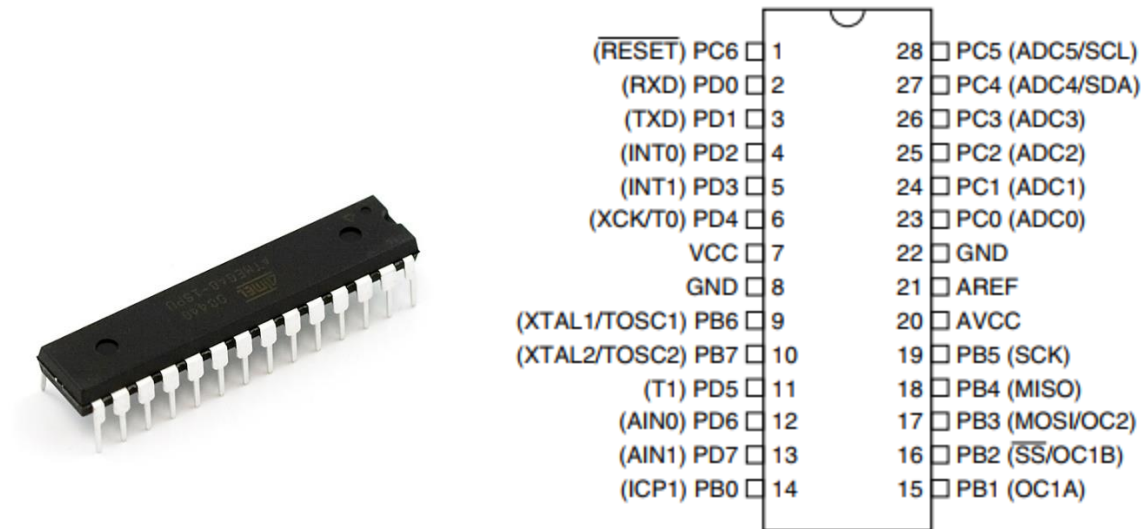

Fig. 3.2 pin diagram of microcontroller ATMEGA 8 (Atmel, 2013)

3.2.1.1 ATMEGA 8 Pin Descriptions

VCC: Digital supply voltage.

GND: Ground.

Port B (PB7..PB0) XTAL1/XTAL2/TOSC1/ TOSC2: Port B is an 8-bit bi-directional I/O port with internal pull-up resistors (selected for each bit). The Port B output buffers have symmetrical drive characteristics with both high sink and source capability. As inputs, Port B pins that are externally pulled low will source current if the pull-up resistors are activated. The Port B pins are tri-stated when a reset condition becomes active, even if the clock is not running

Port C (PC5...PC0): Port C is a 7-bit bi-directional I/O port with internal pull-up resistors (selected for each bit). The Port C output buffers have symmetrical drive characteristics with both high sink and source capability. As inputs, Port C pins that are externally pulled low will source current if the pull-up resistors are activated. The Port C pins are tri-stated when a reset condition becomes active, even if the clock is not running.

PC6/RESET: If the RSTDISBL Fuse is programmed, PC6 is used as an I/O pin. Note that the electrical characteristics of PC6 differ from those of the other pins of Port C. If the RSTDISBL Fuse is programmed, PC6 is used as a Reset input. A low level on this pin for longer than the minimum pulse length will generate a Reset, even if the clock is not running.

Port D (PD7...PD0): Port D is an 8-bit bi-directional I/O port with internal pull-up resistors (selected for each bit). The Port D output buffers have symmetrical drive characteristics with

both high sink and source capability. As inputs, Port D pins that are externally pulled low will source current if the pull-up resistors are activated. The Port D pins are tri-stated when a reset condition becomes active, even if the clock is not running.

RESET: Reset input. A low level on this pin for longer than the minimum pulse length will generate a reset, even if the clock is not running.

The Atmel®AVR® core combines a rich instruction set with 32 general purpose working registers. All the 32 registers are directly connected to the Arithmetic Logic Unit (ALU), allowing two independent registers to be accessed in one single instruction executed in one clock cycle. The resulting architecture is more code efficient while achieving throughputs up to ten times faster than conventional CISC microcontrollers. The ATmega8 provides the following features: 8 Kbytes of In-System Programmable Flash with Read-While-Write capabilities, 512 bytes of EEPROM, 1 Kbyte of SRAM, 23 general purpose I/O lines, 32 general purpose working registers, three flexible Timer/Counters with compare modes, internal and external interrupts, a serial programmable USART, a byte oriented Two wire Serial Interface, a 6-channel ADC (eight channels in TQFP and QFN/MLF packages) with 10-bit accuracy, a programmable Watchdog Timer with Internal Oscillator, an SPI serial port, and five software selectable power saving modes. The Idle mode stops the CPU while allowing the SRAM, Timer/Counters, SPI port, and interrupt system to continue functioning. The Power down mode saves the register contents but freezes the Oscillator, disabling all other chip functions until the next Interrupt or Hardware Reset. In Power-save mode, the asynchronous timer continues to run, allowing the user to maintain a timer base while the rest of the device is sleeping. The ADC Noise Reduction mode stops the CPU and all I/O modules except asynchronous timer and ADC, to minimize switching noise during ADC conversions. In Standby mode, the crystal/resonator Oscillator is running while the rest of the device is sleeping. This allows very fast start-up combined with low-power consumption. The device is manufactured using Atmel's high density non-volatile memory technology. The Flash Program memory can be reprogrammed In-System through an SPI serial interface, by a conventional non-volatile memory programmer, or by an On-chip boot program running on the AVR core. The boot program can use any interface to download the application program in the Application Flash memory. Software in the Boot Flash Section will continue to run while the Application Flash Section is updated, providing true Read-While-Write operation. By combining an 8-bit RISC CPU with In-System Self-Programmable Flash on a monolithic

chip, the Atmel ATmega8 is a powerful microcontroller that provides a highly-flexible and cost-effective solution to many embedded control applications. The ATmega8 is supported with a full suite of program and system development tools, including C compilers, macro assemblers, program simulators, and evaluation kits (Atmel, 2013).

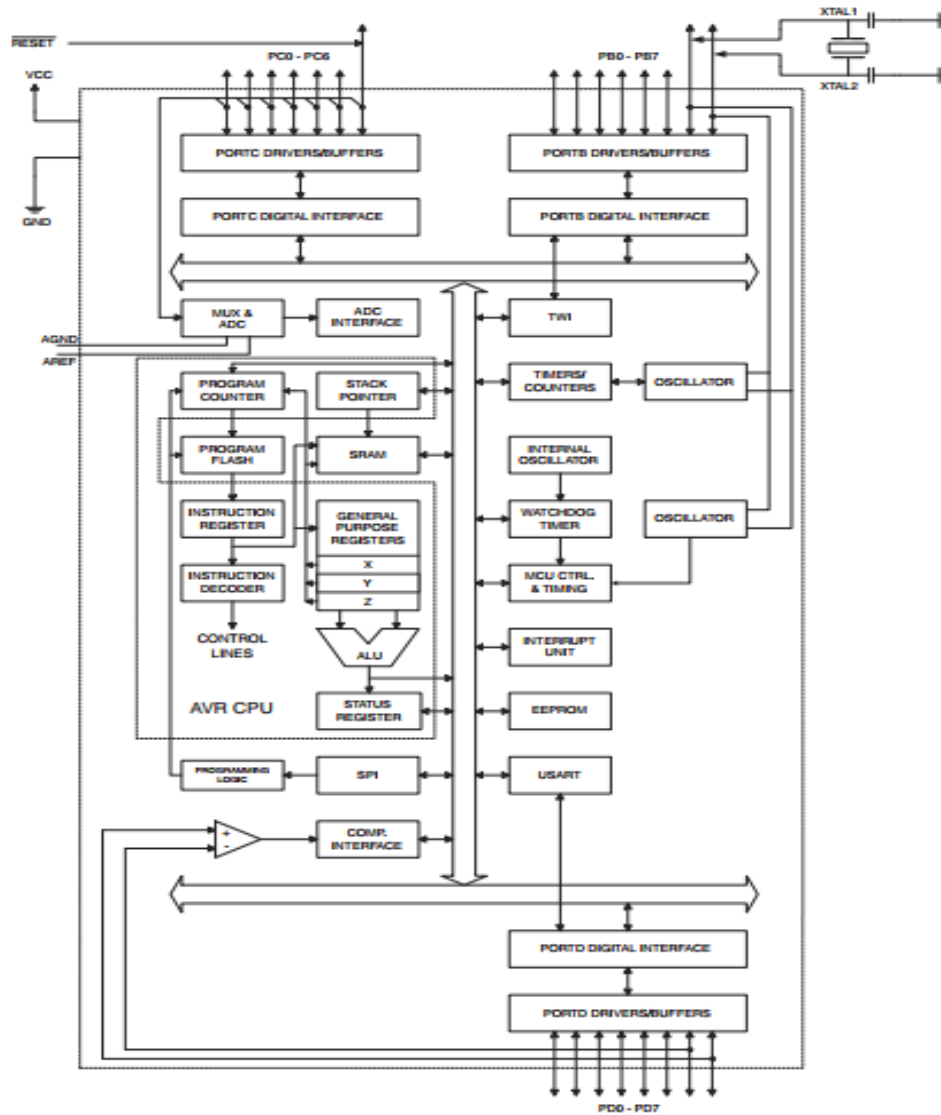

Fig 3.2 Block Diagram ATMEGA 8 (Atmel, 2013)

3.2.2 GPS (GLOBAL POSITIONING SYSTEM)

The Parallax Global Positioning System (GPS) Receiver Module is a fully integrated, low-cost unit complete with onboard patch antenna. Based around the Polestar

(<http://www.polstarGPS.com/>) PMB-248, the GPS Receiver Module is a complete GPS solution in a very small footprint (1.92" long x 1.42" wide).

The GPS Receiver Module provides standard, raw NMEA0183 (National Marine Electronics Association) strings or specific user-requested data via the serial command interface, tracking of up to 12 satellites, and WAAS/EGNOS (Wide Area Augmentation System/European Geostationary Navigation Overlay Service) functionality for more accurate positioning results. The Module provides current time, date, latitude, longitude, altitude, speed, and travel direction/heading, among other data, and can be used in a wide variety of hobbyist and commercial applications, including navigation, tracking systems, mapping, fleet management, auto-pilot, and robotics (Paralax, 2015).

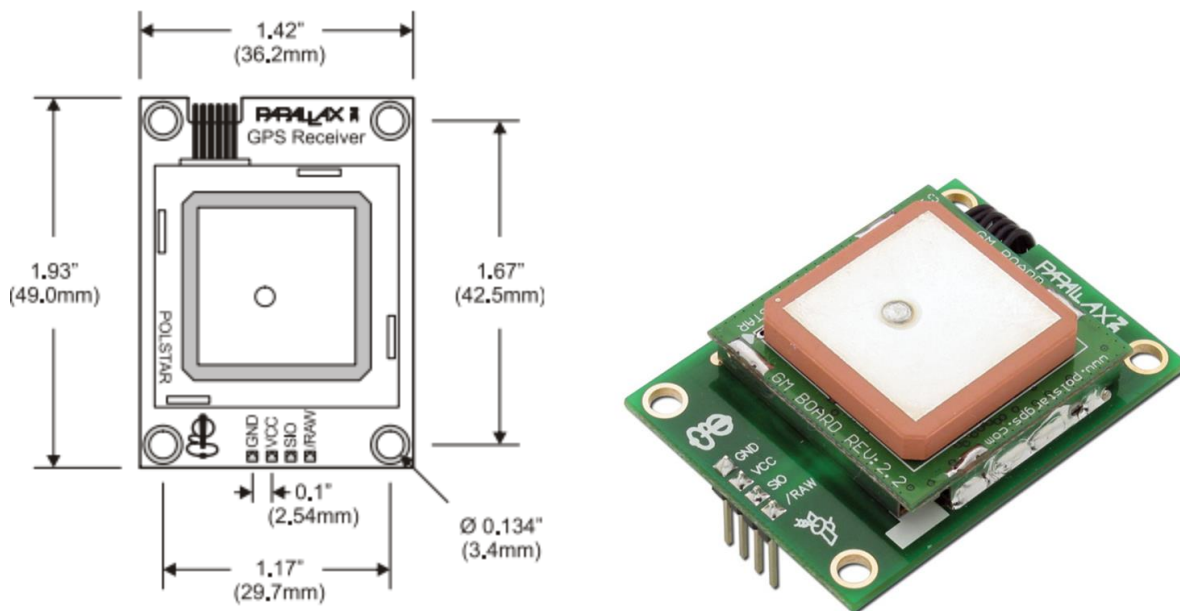

Fig. 3.4 Block and Pictorial Diagram of a Global Positioning System (Paralax, 2015)

3.2.2.1 GPS Module Highlights

- Fully-integrated, low-cost GPS receiver module with on-board, passive patch antenna
- Single-wire, 4800 baud Serial TTL interface to BASIC Stamp®, SX, Propeller, and other processors
- Provides either raw NMEA0183 strings or specific data requested via the command interface
- Requires single +5VDC supply @ 115mA (typical)
- 0.100" pin spacing for easy prototyping and integration Page 1/11 Parallax GPS Receiver Module * Revision 1.1

- Programmable Parallax SX/B microprocessor and open-source control firmware for advanced users (not supported by Parallax, but offered as a download from the Parallax web site)

Electronic Connections

Pin	Pin Name	Type	Function
1	GND	G	System ground. Connect to power supply's ground (GND) terminal.
2	VCC	P	System power, +5V DC input.
3	SIO	I/O	Serial communication (commands sent TO the Module and data received FROM the Module). Asynchronous, TTL-level interface, 4800bps, 8 data bits, no parity, 1 stop bit, non-inverted.
4	/RAW	I	Mode select pin. Active LOW digital input. Internally pulled HIGH by default. When the /RAW pin is unconnected, the default "Smart Mode" is enabled, wherein commands for specific GPS data can be requested and the results will be returned (see the "Command Structure" section for more details). When /RAW is pulled LOW, the Module will enter "Raw Mode" and will transmit standard strings, allowing advanced users to use the raw GPS data directly.

Note: Type: I = Input, O = Output, P = Power, G = Ground

Status Indicators

The GPS Receiver Module contains a single red LED (light-emitting diode) to denote system status. The LED is located in the lower-right corner of the Module. A white overlay on the Module's printed circuit board is used to reflect the light from the LED, making it easier for the user to see. The LED denotes two states of the Module:

- 1) Blinking (both fast and slow): Searching for satellites or no satellite fix acquired
- 2) Solid: Satellites successfully acquired (a minimum of three satellites is required before the Module will begin to transmit valid GPS data)

Upon power up of the GPS Receiver Module in a new location, the Module may take up to five minutes or more to acquire a fix on the necessary minimum number of four satellites. During this time, the red LED on the Module will blink. When enough satellites are acquired for the Module to function properly, the red LED will remain solid red. Due to a variety of conditions, the number of satellites may vary at any given time.

If the LED is OFF, there may be a problem. Please check your wiring and configuration of the Module.

Mode Selection

The /RAW pin allows user selection of the GPS Receiver Module's two operating modes: •
Smart Mode: When the /RAW pin is pulled HIGH or simply left unconnected (the pin is

internally pulled HIGH), the default “Smart Mode” is enabled, wherein commands for specific GPS data can be requested and the results will be returned. See the “Communication Protocol” section for more details. • Raw Mode: When the /RAW pin is pulled LOW, “Raw Mode” is enabled in which the Module will transmit standard NMEA0183 v2.2 strings (GGA, GSV, GSA, and RMC), allowing advanced users to use the raw GPS data directly. For more information on NMEA0183 data, see the “GPS Technology Brief” section. In either mode, data is transmitted at 4800bps, 8 data bits, no parity, 1 stop bit, non-inverted, TTLlevel.

3.2.3 GSM

GSM abbreviates global system for mobile communication, this is a second generation (2G) mobile network. This is widely used in all over the world for mobile communication. This GSM device consists of SIM slot in which a SIM can be inserted which has a unique number, this unique number is used for contact. This GSM device consists a unique number called IMEI number and this is different for each and every hardware kit. In this project the device is used for transmitting data. The data from GPS is transmitted to given mobile through this GSM itself.

SIM800 is a complete Quad-band GSM/GPRS solution in a SMT type which can be embedded in the customer applications.

In this project, SIM800 was employed. SIM800 support Quad-band 850/900/1800/1900MHz, it can transmit Voice, SMS and data information with low power consumption. With tiny size of 24*24*3mm, it can fit into slim and compact demands of customer design. Featuring Bluetooth and Embedded AT, it allows total cost savings and fast time-to-market for customer applications.



Fig 3.5 SIM800 (SIMCOM, 2015)

It is designed for global market, SIM800 is a quad-band GSM/GPRS module that works on frequencies GSM 850MHz, EGSM 900MHz, DCS 1800MHz and PCS 1900MHz. SIM800 features GPRS multi-slot class 12/ class 10 (optional) and supports the GPRS coding schemes CS-1, CS-2, CS-3 and CS-4.

With a tiny configuration of 24*24*3mm, SIM800 can meet almost all the space requirements in users' applications, such as M2M, smart phone, PDA and other mobile devices.

SIM800 has 68 SMT pads, and provides all hardware interfaces between the module and customers' boards. (SIMCOM, 2015)

- Support up to 5*5*2 Keypads.
- One full function UART port, and can be configured to two independent serial ports.
- One USB port can be used as debugging and firmware upgrading. λ Audio channels which include a microphone input and a receiver output.
- Programmable general purpose input and output.
- One SIM card interface. λ Support Bluetooth function.
- Support one PWM.
- PCM/SPI/SD card interface, only one function can be accessed synchronously. (default is PCM) SIM800 is designed with power saving technique so that the current consumption is as low as 1.2mA in sleep mode.

SIM800 integrates TCP/IP protocol and extended TCP/IP AT commands which are very useful for data transfer applications

The following figure shows a functional diagram of SIM800:

- GSM baseband engine
- PMU λ RF part
- Antenna interfaces
- Other interfaces

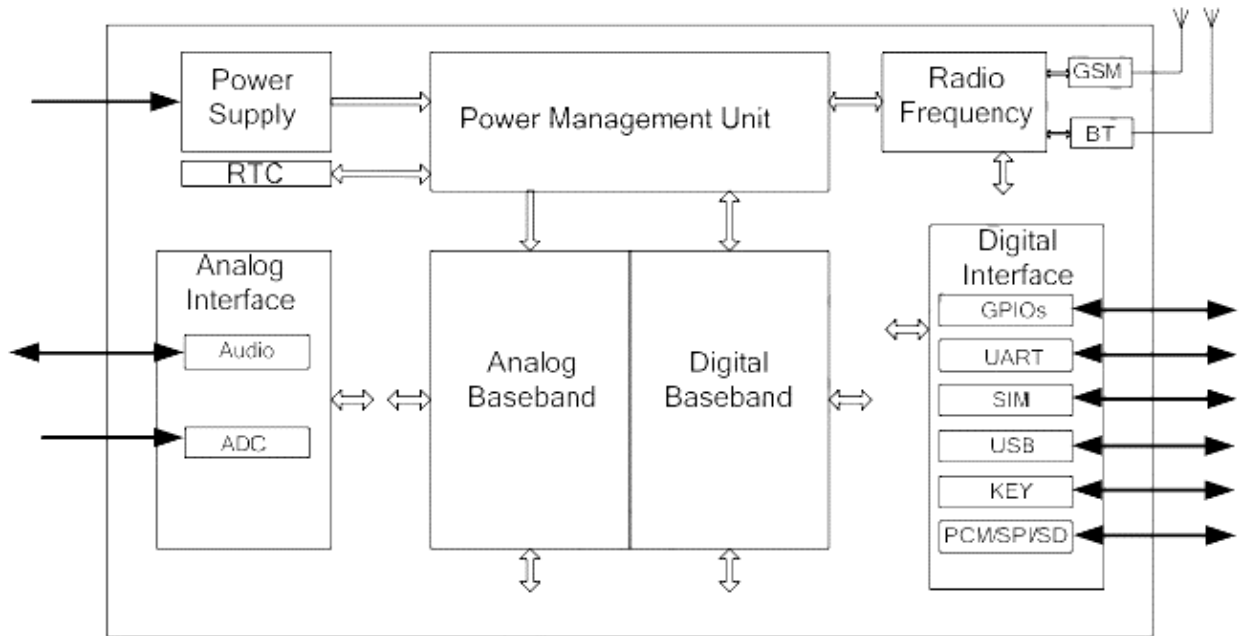

Fig. 3.6: SIM800 functional diagram (SIMCOM, 2015)

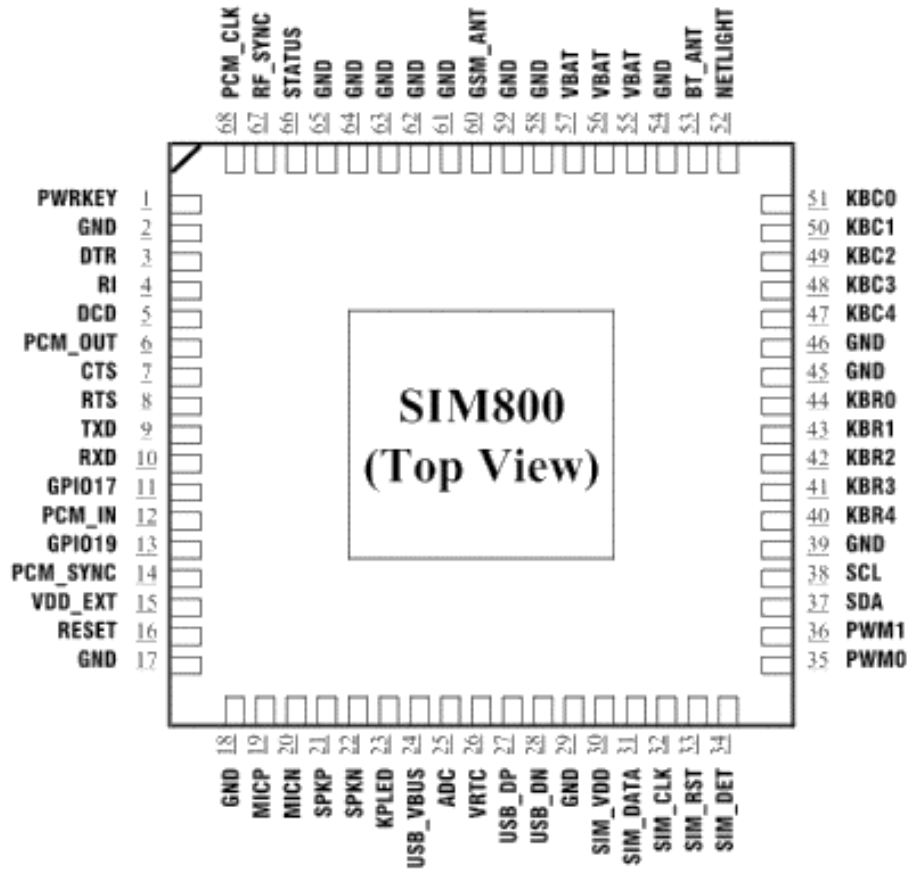

Fig 3.6.1: SIM800 pin out diagram

3.2.4 POWER SUPPLY

The power supply section is very important for all electronic circuits. The 230V, 50Hz AC mains is stepped down by transformer X1 to deliver a secondary output of 12V, 500 mA. The transformer output is rectified by a full-wave rectifier comprising diodes D1 through D4, filtered by capacitor C1 and regulated by ICs 7812 (IC2) and 7805 (IC3). Capacitor C2 bypasses the ripples present in the regulated supply. LED1 acts as the power indicator and R1 limits the current through LED1. The power supply section is shown in the figure below.

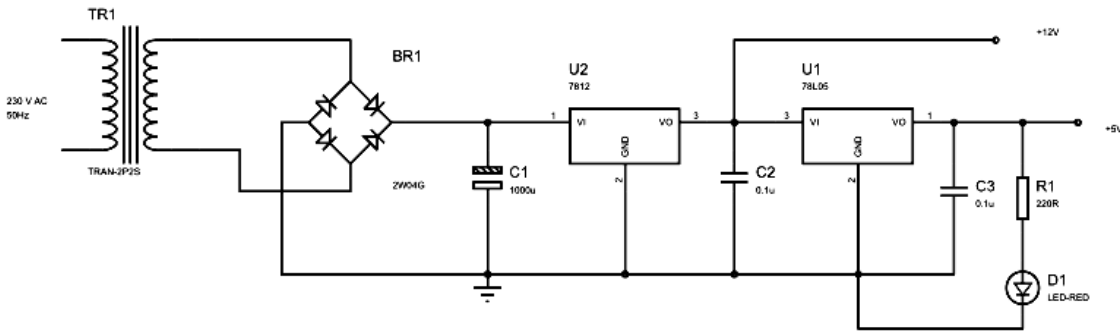

Fig 3.7 Power supply



Fig 3.8 Pictorial representation of Power supply

3.3 PROCEDURES OF DESIGN AND CONSTRUCTION

A microcontroller-based system is a complex activity that involves hardware and software interfacing with the external world. Doing well design of a microcontroller-based system requires skills to use the variety of debugging and testing tools available. The debugging and testing of microcontroller-based systems divided into two groups: software-only tools and software-hardware tools. Software-only tools come as monitors and simulators, which are independent of the hardware under development. Software-hardware tools are usually hardware dependent, more expensive and range from in-circuit emulators and in-circuit simulators to in-circuit debuggers. In general, the higher the level of integration with the target hardware, the greater the benefit of a tool, resulting in a shorter development time, but the greater the cost as well. The factors to consider when choosing a debugging tool are cost, ease of use and the features offered during the debugging process.

A software simulator is a computer program running on an independent hardware and it simulates the CPU, the instruction set and the I/O of the target microcontroller. Simulators offer the lowest-cost development tools for microcontroller-based systems and most companies offer their simulator programs free of charge. The user program operated in a simulated environment where the user can insert breakpoints within the code to stop the code and then analyze the internal registers and memory, display and change the values of program variables and so on. Incorrect logic or errors in computations can analyze by stepping through the code in simulation. Simulators run at speeds 100 to 1000 times slower than the actual micro controller hardware and, thus, long time delays should avoid when simulating a program. Micro controller-based systems usually have interfaces to various external devices such as motors, I/O ports, timers, A/D converters, displays, push buttons, sensors and signal generators, which are usually difficult to simulate. Some advanced simulators, such as the Proteus from Lab center Electronics allow the simulation of various peripheral devices such as motors, LCDs, 7-segment displays and keyboards, and users can create new peripheral devices. Inputs to the simulator can come from files that may store complex digital I/O signals and waveforms. Outputs can be as form of digital data or waveforms, usually stored in a file, or displayed on a screen. Some simulators accept only the assembly language of the target microcontroller. Most of the microcontroller software has written a high-level language such as C, Pascal or Basic, and it has become necessary to simulate a program has written in a high-level language. The software program has written in c

or assembly language and compiled using Keil software. After compiler operation, the hex code generated and stored in the computer. The hex code of the program should be loaded into the AT89C52 by using Top win universal programmer. STEP TO STEP PROCEDURES:

- ✓ First step, we need to make single side PCB layout for the given circuit diagram. After made the PCB the following process is required to complete the project.
- ✓ Assemble all the components on the PCB based on circuit diagram. TX and RX pins of the GSM modem to pins 13 and 14 of MAX 232 and insert a valid SIM in the GSM modem.
- ✓ Connect the GPS module according to circuit diagram.
- ✓ The projects implemented and tested successfully by me
- ✓ This system is very useful and secure for car owners.

The complete circuit diagram of the VAAT system using GPS and GSM technology is shown in Fig.3.9. The compact circuitry is built around Atmel ATMEGA8 microcontroller. The ATMEGA8 is a low power; high performance CMOS 8-bit microcomputer with 8 kB of Flash programmable and erasable read only memory (PEROM). Other modules and components are wired as illustrated in the diagram.

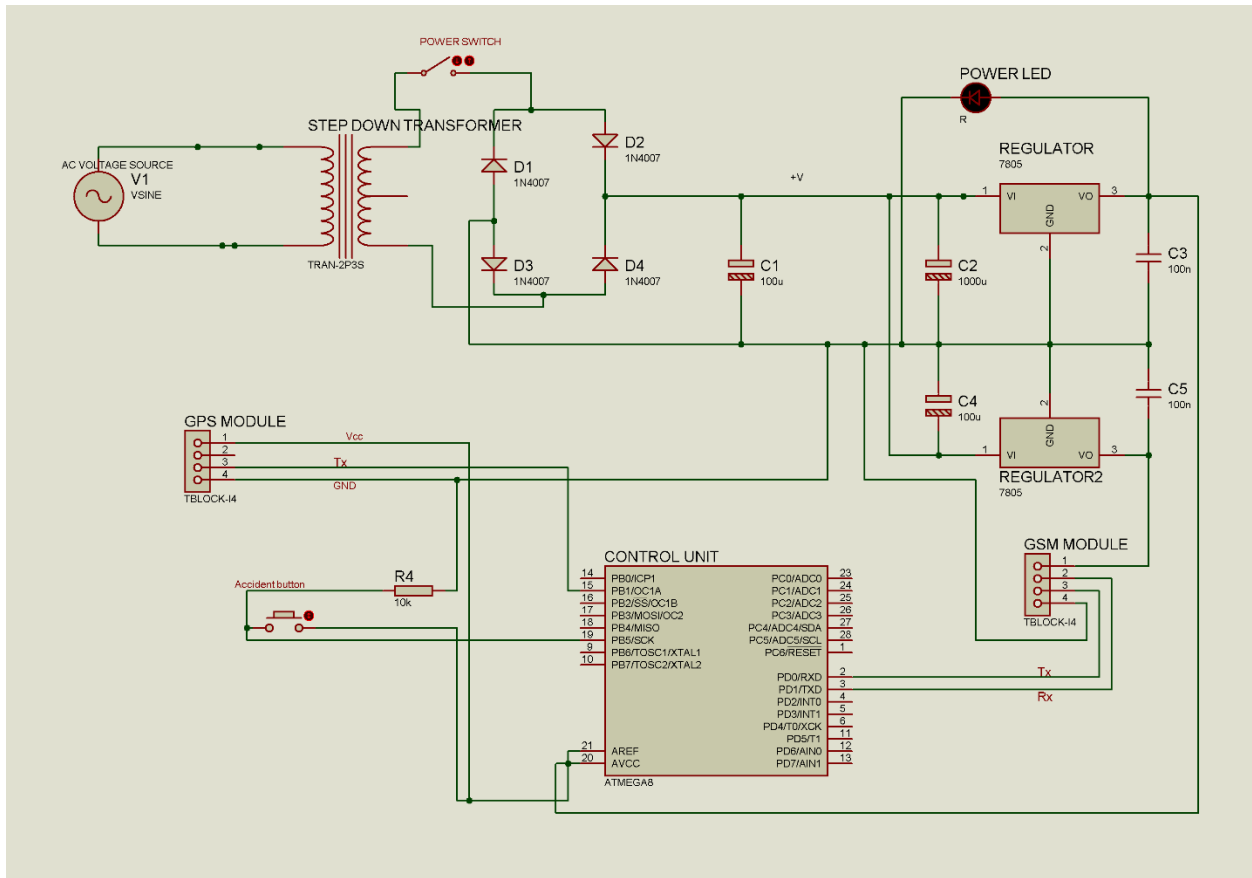

Fig. 3.9: complete Circuit Diagram of VAAT system

3.4 WORKING PRINCIPLE OF THE VEHICLE TRACKING AND ACCIDENT ALERT

This system takes input from GPS and which goes into rs232. This Rs232 sends data into max232 and it converts the data format and sends it to the Rx (receiver pin) of microcontroller and this microcontroller stores this data in USART buffer and the data stored is sent again through Tx pin into max232 this max 232 sends the data into GSM via rs232. This is how vehicle tracking works using GSM and GPS. While the Accident in the sense it could be collision of two vehicles or fire accident inside the vehicle. These push buttons are attached to the air bag of the car at the steering wheel, as the accident occurs the push button sends a message about the accident to the registered GSM mobile with the help of the microcontroller.

3.5 SYSTEM ARCHITECTURE

The Accident Alert and Tracking System is the system which track vehicle current location using global positioning system (GPS).This product gives the live updates of accidental vehicle

with their location details. It ensures the vehicle which has got accident to send location details to web server located at emergency ambulance center further that location details of accidental vehicle send to nearby ambulance as well as display it on map. As per the system architecture, Accident Alert and Tracking System is working same as follows. When the accident will occurred, then the system will direct send the accident alert message along with location details of the accidental vehicle to emergency dispatch sever further it will send that alert message to the nearby ambulance so that it will go to that location. By using system like this we can decrease the mortality rate which is led by accident.

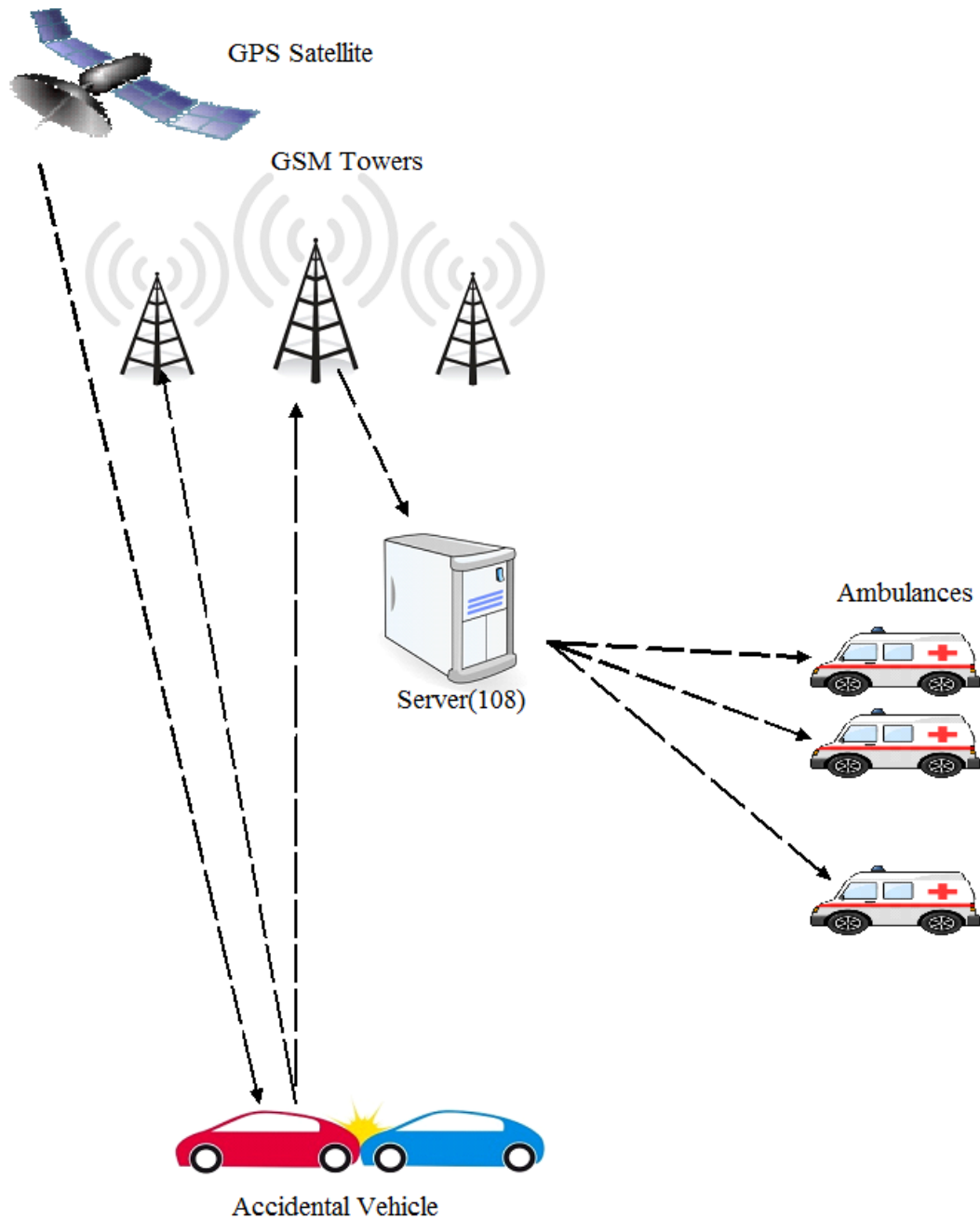

Fig. 3.10: System architecture

This system is a prototype model of Accident Alert and Vehicle Tracking System using GSM and GPS modem and Raspberry Pi working will be made in the following steps:

- ✓ A piezoelectric sensor will first sense the occurrence of an accident and give its output to the microcontroller.

- ✓ The GPS detects the latitude and longitudinal position of a vehicle.
- ✓ The latitudes and longitude position of the vehicle is sent as message through the GSM.
- ✓ The static IP address of central emergency dispatch server is pre-saved in the EEPROM.
- ✓ Whenever an accident has occurred the position is detected and a message has been sent to the pre-saved static IP address.

4 CHAPTER FOUR

4.1 TESTING, ANALYSIS OF RESULTS AND DISCUSSIONS

4.1.1 Hardware Assembling and Testing:

First step taken was creating flux board layout for the circuit diagram. After then, the following steps were then followed.

1. Assemble all the components on the flux board based on circuit diagram. TX and RX pins of the GSM modem to pins 13 and 14 of MAX 232 and insert a valid SIM in the GSM modem.
2. Connect the GPS module according to circuit diagram.
3. The project was implemented and tested successfully.
4. This system is very useful and secure for car owners.

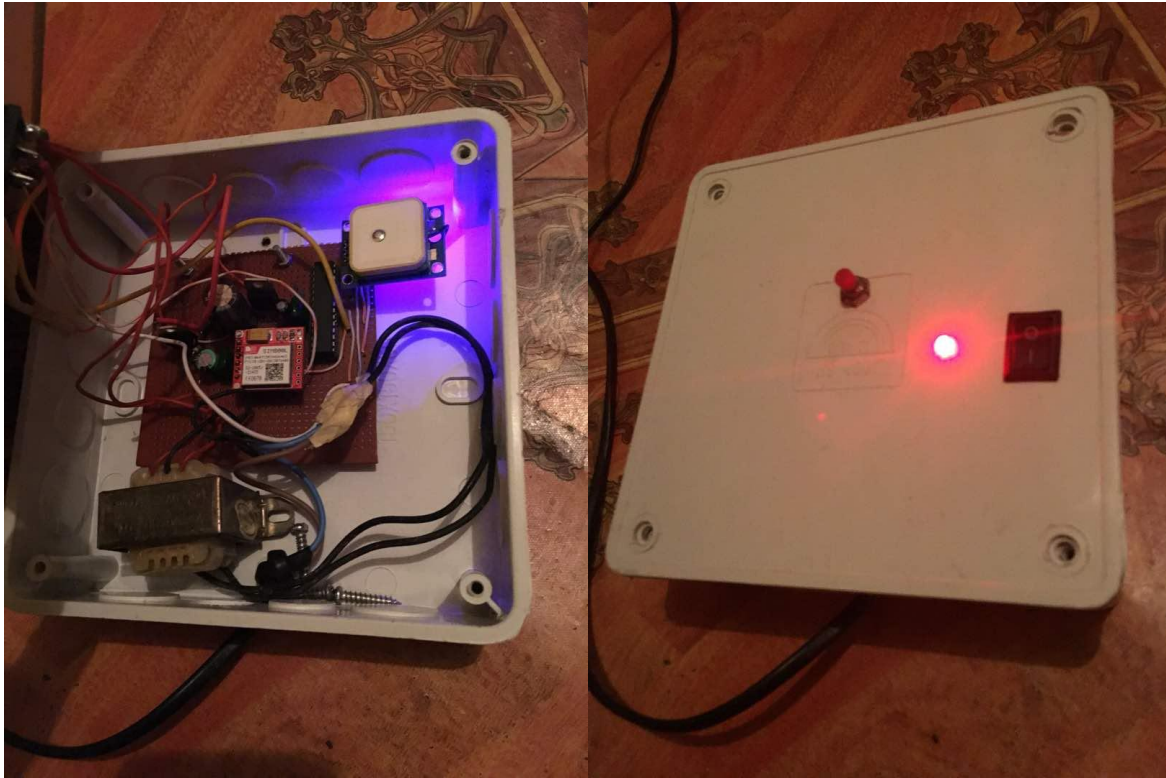

Fig 4.1: view of project during testing and evaluation

4.2 RESULTS

For monitoring the vehicle location whenever there is an accident or theft of the vehicle, I have included the feature which will send SMS to the user according to user request. SMS will be included the value of latitude and longitude of the vehicle. A link is also attached with the SMS, so that the user can see the location by using Google map.

Message for theft:

User sends: location

Devise responds with the link (Google API) containing the coordinate in point of the device

Message for accident: Accident Alert!!!

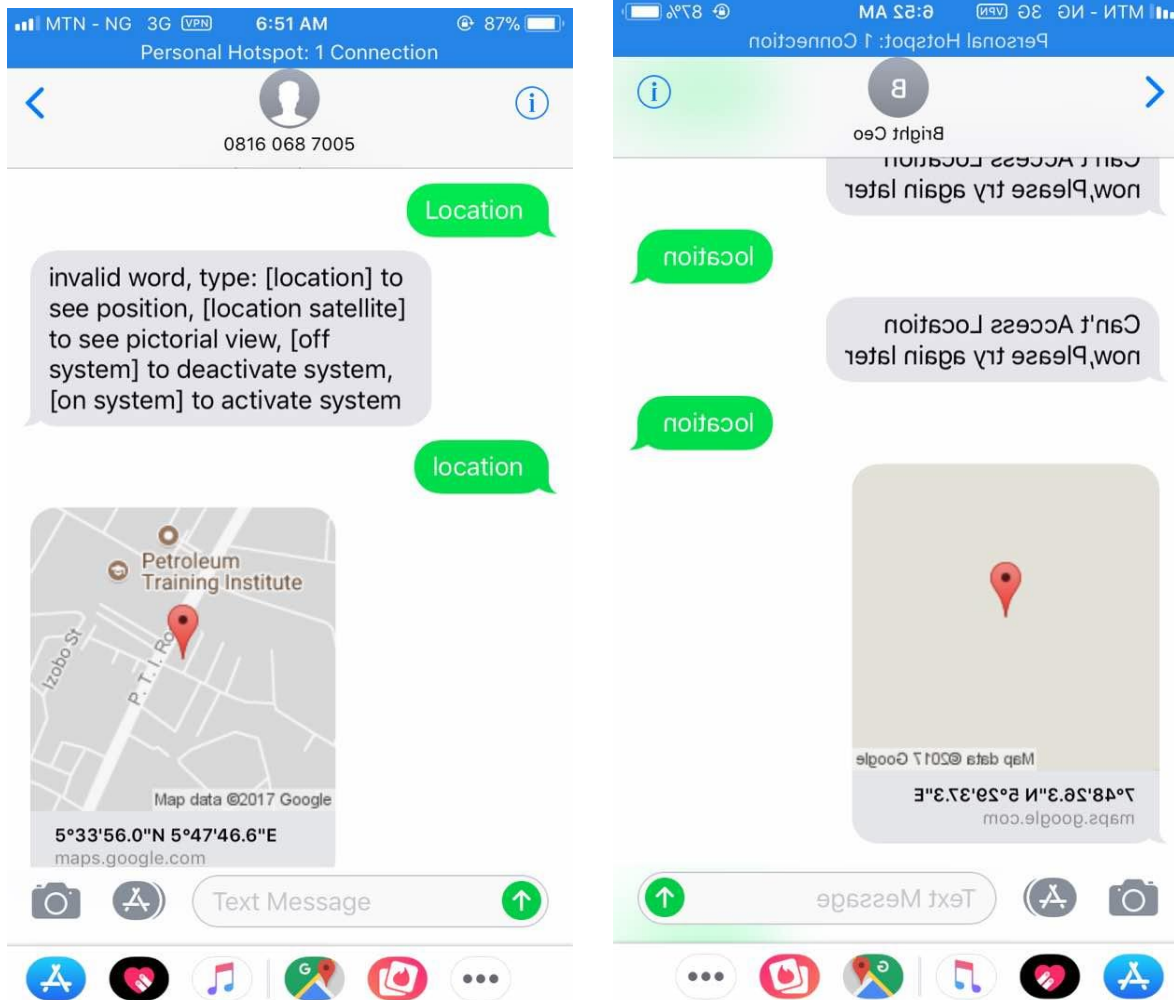

Fig 4.2: view of communication between user and VTAA system via text message

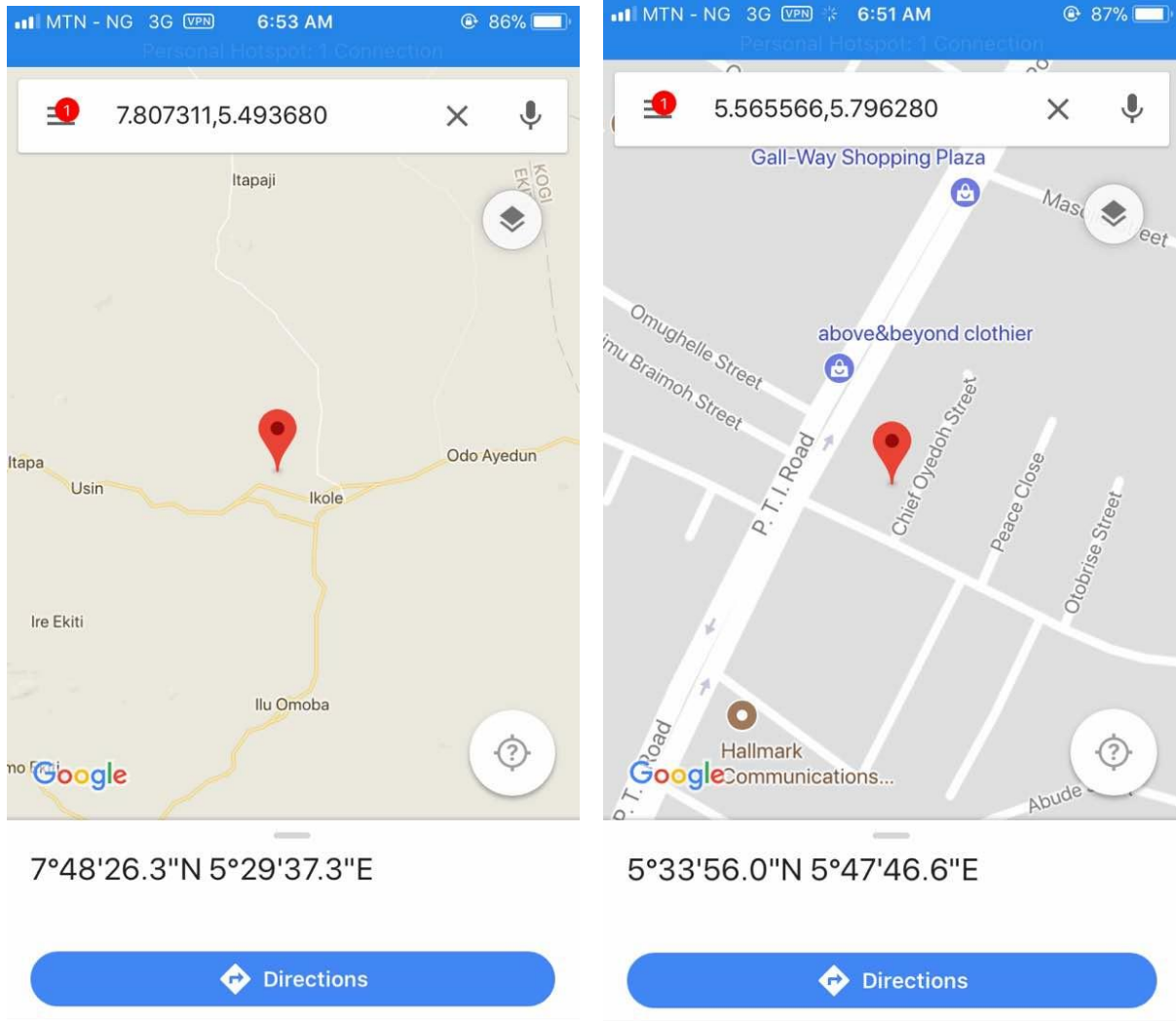

Fig 4.3: View of location on website through Google map

4.3 PERFORMANCE EVALUATION

While testing the whole setup I also observed the delay analysis. That is I observed the time it takes for the in-vehicle device to reply or send an SMS in response to end user's demand. For such observation of this delay analysis, we used SIM cards 6555556UU of four different operators and recorded the delay for each of the corresponding SIM cards in pair. Four different operator SIM cards that we have used are MTN, 9MOBILE, Glo and Airtel. Different sets of data are recorded and corresponding average time is considered to study the delay analysis. The results are shown below:

4.3.1 PERFORMNCE ANALYSIS USING DIFFERENT SIM

Table 4.1: SIM in GSM module fixed MTN

SIM IN GSM MODULE	SIM IN USER END	DELAY
MTN	MTN	49 Seconds
MTN	GLO	1 minutes 41 seconds
MTN	AIRTEL	1 minutes 32 seconds
MTN	9MOBILE	1 minutes 50 seconds

Table 4.2 SIM in GSM module fixed Airtel

SIM IN GSM MODULE	SIM IN USER END	DELAY
AIRTEL	MTN	1 minutes 26 seconds
AIRTEL	GLO	1 minutes 30 seconds
AIRTEL	AIRTEL	54 seconds
AIRTEL	9MOBILE	1 minutes 41 seconds

Table 4.3: SIM in GSM module fixed GLO

SIM IN GSM MODULE	SIM IN USER END	DELAY
GLO	MTN	1minutes 58 seconds
GLO	GLO	1minutes 37 seconds
GLO	AIRTEL	2minutes 9seconds
GLO	9MOBILE	2minutes 14 seconds

Table 4.4: SIM in GSM module fixed 9MOBILE

SIM IN GSM	SIM IN USER END	DELAY
9MOBILE	MTN	1minutes 36 seconds
9MOBILE	GLO	1 minutes 37seconds
9MOBILE	AIRTEL	1 minutes 41 seconds
9MOBILE	9MOBILE	1minutes 42 seconds

Speed of communication between device and User terminal(s) is a cogent factor for good performance of VTAA system. The tables above is the result of analysis carried out during performance testing at the Electrical and Electronics Departmental Laboratory, Federal

University OYE-Ekiti, Ekiti State. These Tables illustrates the delay in communication between the major service providers (MTN, GLO, AIRTEL and 9MOBILE) in Nigeria. The Chart below compares each service provider and their commination delay graphically.

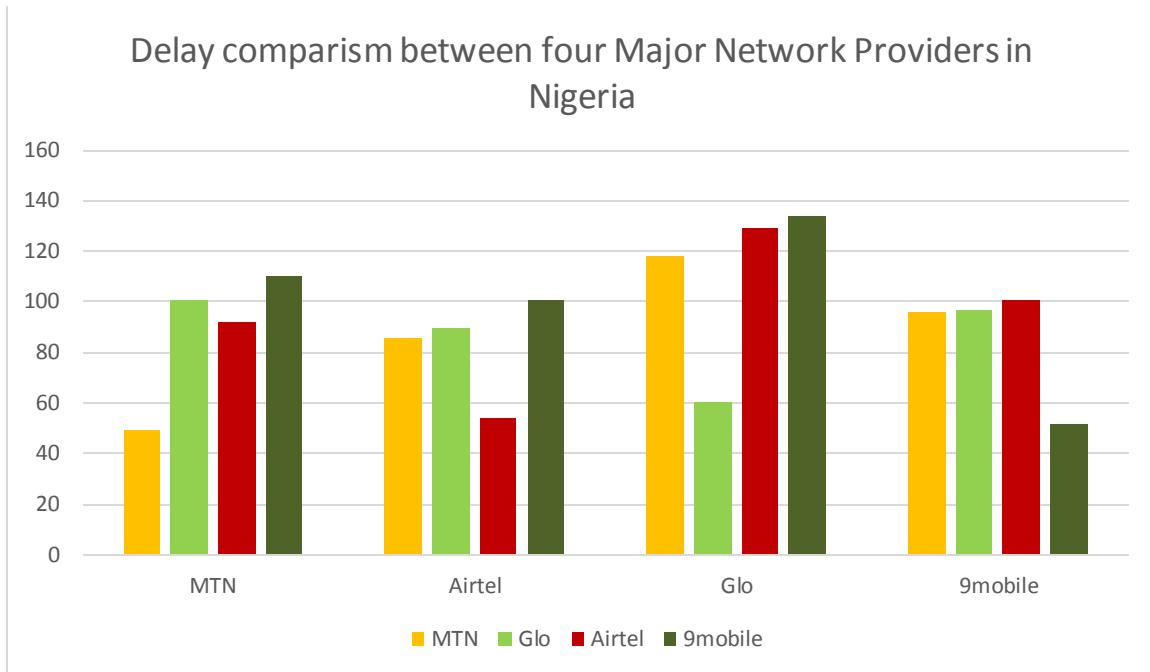

From the above analysis, it is observed that there is nearly 1.5 minutes to 2 minutes delay for each set of data of different operator and this time delay seem to be less significant. Network dependency on the GSM service provider of this GSM based technology is one of reasons for such delay. This is because while the vehicle is traveling, it passes through certain areas of poor network coverage. From point of research, MTN to MTN communication seem to be the one with the minimal delay (49 seconds). Considering this observation, MTN network service provider was used in both the sending and the receiving terminal of the project i.e. Communication in form of Short Message Service (SMS) is made between two MTN service providers, one in User terminal (GSM system) and the other in the device (VTAA system).

4.3.2 BENEFITS AND APPLICATION OF VAAT SYSTEM

The in-vehicle tracking device or unit working along with a central server and a software, which let the user or owner of a car to know the whereabouts of his own vehicle, surely comes with several benefits.

- ✓ The GPS and GSM installed inside the vehicle fetches its location information and send it to owner on regular intervals according to user's preferences, in order to remain up-to-date all the time.
- ✓ As all the relevant information is sent, it is very convenient for the user to monitor and take any actions in case of an emergency.
- ✓ Also monitoring discourages dangerous and inefficient driving practices of drivers which lead to increased vehicle security and driver safety.
- ✓ The vehicle tracking system plays a vital role if it is used in any companies or organization for any kind of delivery purposes. Since the driver is being aware of the fact that the car is constantly being monitored so one would be careful while driving and take shortest possible route to reach destination right on time.
- ✓ This system can also be named as an anti-theft tracking system as this advanced yet affordable system ensures the recovery of stolen vehicles too. If the car does not get to designated location or being used by unauthorized user, the location can be traced and then notified to police to reach the unauthorized location where the vehicle is residing and thus this vehicle tracking system ensures car safety as well.

4.4 PROJECT MANAGEMENT

The project had various tasks that were carried from commencement to completion. A Gantt chart was developed to keep track of project progress. Project tasks were listed against their estimated start and completion times to accurately complete the project within the estimated time. However there were delays in the implementation of the project due to the fact that SIM908 was not readily available in the local market and had to be imported which took a long time almost a month. The Gantt chart used was as below:

4.4 GANTT CHART

Table 5: Gantt chart illustrating project activities and duration.

		WK 2	WK 3	WK 4	WK 5	WK 6	WK 7	WK 8	WK 9	WK 10	WK 11	WK 12	WK 13	WK 14	WK 15	WK 16	WK 17
TASK 1																	
TASK 2																	
TASK 3																	
TASK 4																	
TASK 5																	
TASK 6																	
TASK 7																	

Task 1- Project research work

Task 2- Design of project circuit prototype

Task 3- source code development

Task 4- purchase of components and tools needed for the project

Task 5- construction of circuit on a bread board

Task 6- permanent soldering on a Vero board

Task 7- project packaging and performance review

The breakdown in the chat above describe the sequential activities carried out to the achievement of this project. The span for the project was approximated to seventeen weeks, the structure did not follow each other in a successive manner but each allotted time took into consideration all factors required in executing the task including the likely problems to occur and subsequent troubleshooting measures.

4.5 Risk Management

4.5.1 Hackers

The data created by GPS can be stored on a computer. Even the best computer security systems can be compromised. This can lead to personal data becoming available to criminals. The information provided by the GPS can tell criminals user schedules or areas visited to frequently. Certain GPS work with vehicles and complete functions on the car.

4.5.2 Surge and thunder effect

Surge, thunder and other natural effect are major factors that could prone the VAAT system to risk of damage since the modules involved communicate with satellite and operate in microwave frequency. This effect is naturally mitigated with the skin effect principle. At lightning of higher frequencies, currents are carried mostly on the outside of conducting objects. A thick copper wire or a hollow-wall metal pipe will carry most of the lightning on outer surfaces. This phenomenon is called "skin effect." The same holds true for lightning when it strikes metal vehicles: the outer surface carries most of the electricity. The VAAT system inside this polyvinyl chloride (PVC) made box can be likened to protect by a partial Faraday cage.

4.6 Ethical Issues

GPS stands for Global Positioning System, and is a series of satellites orbiting around the Earth that provide real-time information on a location of a GPS receiver. A GPS that only receives direction information does not raise ethical questions. It is the systems that also relay the location information to a third party that raises ethical issues.

4.6.1 Privacy

GPS systems that transmit the location of individuals infringe on an individual's right to privacy. These systems are providing information about the whereabouts of an individual without their consent. All drivers should feel safe in their vehicle without concerns that their current whereabouts are being transmitted to a third party that can choose to do with the information as

its pleases. This information could be sold to companies or used by law-enforcement officials to verify an individual's location at a certain time. The privacy in the project is then increased by specifying in other words limiting the users that could communicate with the VAAT system to just three trusted personnel which are the Vehicle Owner, Next of Kin and Central Emergency Agency.

4.6.2 Data Ownership

The satellites used for GPS were created by the government to track military personnel. These same satellites are used to convey GPS information to drivers and third parties. The question arises as to who actually owns the data produced through the system. Does the individual owning the GPS unit own the information? Or the government that created the satellite, or the third party who is gathering the data? If the government owns the information, it opens the door to the government being able to track vehicle movements without consent and possibly without a warrant or reason.

5 CHAPTER FIVE

5.1 CONCLUSIONS

Vehicle tracking system makes better fleet management and which in turn brings large profit. Better scheduling or route planning can enable us handle larger job loads within a particular time. Vehicle tracking both in case of personal as well as business purpose improves safety and security, communication medium, performance monitoring and increases productivity. So in the coming year, it is going to play a major role in our day-to-day living.

Main motto of the accident alert system project is to decrease the chances of losing life in such accident which we can't stop from occurring. Whenever accident is alerted the paramedics are reached to the particular location to increase the chances of life. This device invention is much more useful for the accidents occurring in deserted places and midnights. This vehicle tracking and accident alert feature plays much more important role in day to day life in future. In my thesis I have developed a vehicle tracking system that is flexible, customizable and accurate. The GSM modem was configured and I tested and implemented the tracking system to monitor the vehicle's location via SMS and online on Google map. To display the position on Google map I have used Google map API. The microcontroller is the brain of the system and the GSM modem is controlled by AT commands that enable data transmission over GSM network while the GPS provide the location data. Whenever the GPS receives a new data it is updated in the database and hence the location is viewed on Google map. The system provides accurate data in real time that makes it possible for the user to track the vehicle and it also enables an early retrieval if the car is stolen. This thesis has widely increased my knowledge of GPS and also improved my programming skills.

5.2 LIMITATIONS

While this advanced technology based tracking system can benefit users, company or any organization, there are also some limitations to using this vehicle tracking devices.

- ✓ Often GPS takes time to connect with the network due to poor weather conditions. For the GPS to work properly, it needs to have a clear view of the sky. That is it is unlikely to work indoor or may even have problem outside where it has no clear path of transmitting to and receiving signal from satellites. Therefore, due to obstacles like tall buildings or such infrastructure which block view of the sky, often causes multipath error to the

receiving signal of the GPS receiver. As a result, location seems to appear to jump from one place to another leading to inaccurate results. Thus incorrect values of latitude and longitude are sent to the server, for displaying in the Google map on error being initialized.

5.3 FUTURE WORK

The recommendations for future work are as follows:

- ✓ Investigate how to protect the data collected on the website by making sure users only get to access only those devices that they are authorized to. Generally increased security to protect Vehicle tracker identity.
- ✓ To develop a mobile application for the different types of mobile Operating Systems rather than just using a desktop application.
- ✓ Developing a means to show track record of where the vehicle has been rather than just the position it is located.

5.4 Design Constraints

The accuracy of this system will depend on number of BTSs in a particular tracking area; so, the higher the number of BTSs (Base Transceiver Systems), the greater the accuracy. This system will accurately work at certain regions according to above constraint. The response time of the proposed system also depends on the response time of the GSM network and the LBS (Location Based Service). It is assumed that the LBS will always give accurate location information upon requests. It is also assumed that availability and accessibility of GSM network and its backend system are high and there is no down time in the GSM network and the LBS. It is also assumed that, the system might diverse from its normal operation under the circumstances of low signal strength areas such as inside tunnels and subways. The system might not perform well under extreme conditions such as high voltage and high noise areas which may cause to damage the strength of the microwave signals.

5.5 Contribution to knowledge

The major contribution to knowledge established by this project based on research is the addition of an Accident Alert System and the approach applied towards achieving it. The push button added to the system that signals an accident at burst of airbag makes the VTAA system to be a more advanced form of the conventional vehicle tracking system.

5.6 Critical appraisal

The design work carried out for Vehicle Tracking and accident alert system was the major challenge in the entire development process. Owing to limitations observed in previous method employed, it was quite difficult to reach the method employed in this project as illustrated in Methodology (CHAPTER THREE). This method is cheaper and of a better utility. Software simulation using Proteus was very challenging as the modules are not readily available on the software. I was able to scale through after hours of research by downloading a library for each module and installing through the software, then finally conduct the simulation as shown in Figure3.2. The virtual GPS readings (point coordinates) were observed and the ideal behavior of the system was confirmed before making breadboard connection.

The design of this system has helped in broadening my horizon on circuit designs and difference in signal strengths by local networks. This design has also taught me the importance of certain components in circuits, their respective roles, and how to use them as an interface to a microcontroller in a coordinated manner.

REFERENCES

- Albert Alexe, R., Ezhilarasie. (2011). *Cloud Computing Based Vehicle Tracking Information System Sysytem*.
- Alex P., Kiran, S., Piraji, D., Imran. (2011). Cloud Computing Based Vehicle Tracking Information Systems. *Cloud Computing Based Vehicle Tracking Information Systems*.
- Al-Hindawi, A., M. (2012). Experimentally Evaluation of GPS/GSM Based System Design. *Electronic Systems, Volume 2*.
- Asaad M., J., Al-Hindawi, Ibraheem Talib. (2012). Experimentally Evaluation of GPS/GSM Based System Design. *Electronic Systems*.
- Ashutosh Upadhaya. (2014). *Tracking System Using GSM, GPS & Arm7*. Bombe.
- Atmel. (2013). Datasheet. 1-331.
- Benjamin B., K. (2013). A Real-Time Computer Vision System for Vehicle Tracking and Traffic Surveillance, Transportation. *Transportation*.
- Chen Peijiang, Jiang Xuehua. (2008). *Design And Implementation of Remote Motoring System Based on GSM*.
- Coifman, B. (2013). *A Real-Time Computer Vision System for Vehicle Tracking and Traffic Surveillance*.
- Global Sytem For Mobile Communication. (2016). <https://en.wikipedia.org/wiki/GSM#history>.
- Henster D. R. (2012). Embedded Smart Car Security System on Face Detection. *Special Issue of Ijct*.
- Kai-Tai Song. (2005). Front Vehicle Tracking using Scene Analysis". *Proceedings of the IEEE International Conference on Mechatronics & Automation*.
- Khalifa A. Salim P., Kiran, S., Piraji, D., Imran. (2013). Web Based Vehicle Tracking System. *ISSN: 2231-0711 443iv*. (Pp. Issue 12, 443-448). Ijcset.
- Kiran Sawant, Imran Bhole, Prashant Kokane, Piraji Doiphode, Prof. Yogesh Thorat. (2015). *Accident Alert And Vehicle Tracking System*. Bangladesh: [Www.Researchpublish.Com](http://www.researchpublish.com).
- Kokane, P., Kiran, S., Piraji, D., Imran, 4., & Thorat, P. Y. (2015). Review On Accident Alert And Vehicle Tracking System. *International Journal of Computer Science And Information Technology Research*, 259-263.

- Kunal Maurya. (2006). [Real Time Vehicle Tracking System Using GSM And GPS Technology- An Anti-Theft Tracking System. ” *International Journal of Electronics And Computer Science Engineering*.
- Nairaland.Com. (2016).
- Paralax. (2015). Paralax GPS Module Data Sheet.
- R. Ramani, (2013). *Vehicle Tracking and Locking System*.
- R Ramya, (2012). Embedded Controller for Vehicle in-Front Obstacle Detection and Cabin. *International Journal Of Computer Science & Information Technology (Ijcsit)*.
- Simcom. (2015). Sim800_Hardware Design_V1.08 .
- Simcom Tech Company. (2011). *Sim908 AT Command Manual*. China.
- U.S. Department Of State. (2013). Global Positioning System (GPS) And Its Applications. *United Nations/Croatia Workshop On The Applications Of Global Navigation Satellite Systems*. Baska, Krk Island, Croatia: U.S. Department Of State.
- V.Ramya. (2012). Embedded Controller For Vehicle In-Front Obstacle Detection And Cabin Safety Alert System. *International Journal of Computer Science & Information Technology (Ijcsit)*.
- Weberience llc. (2017). *Steeple analysis*. Pestleanalysis.com: wpengine.
- Wikipedia. (2016). *GSM*. <https://en.wikipedia.org/wiki/GSM#history>.

APPENDIX

Operational Flow Chart

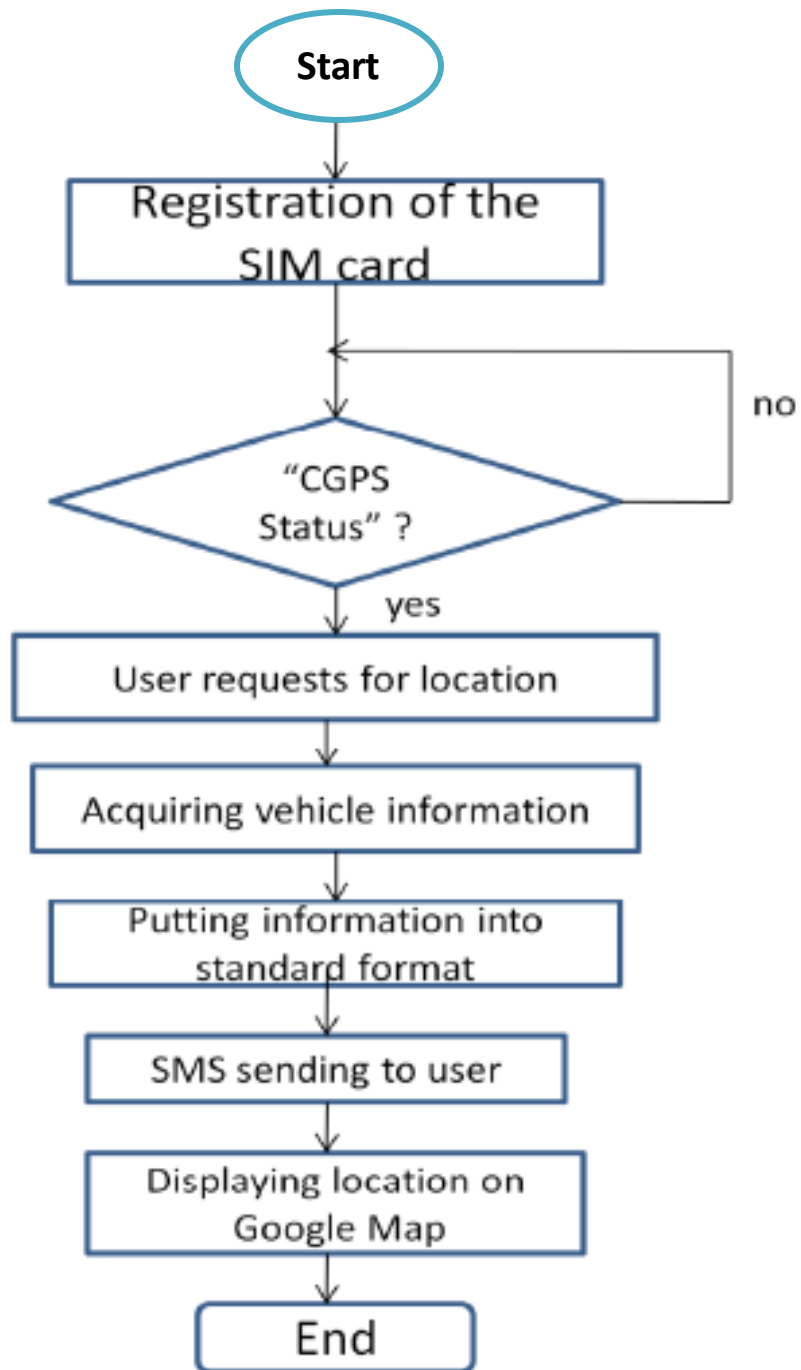

Cost Evaluation Table

The table below shows cost analysis of components and materials acquired for construction of the project.

S/N	Component description	Quantity	Amount in Naira	Total in Naira
1	ATMEGA8 Microcontroller	1	1500	1500
2	GPS module	1	5000	5000
3	GSM module (SIM 800)	1	5500	5500
4	VERO Board	1	200	200
5	Jumper Cables	1 set	100	100
6	Resistors	6	10	60
7	Capacitors 1000uf/3v	5	10	50
8	Transformer 9v	1	3000	3000
9	Casing	1	6000	6000
10	Ceramic capacitor 104f	6	10	60
11	Voltage Regulator	1	500	500
Grand Total				21950

Source code:

```
#include<stdio.h>
#include<stdlib.h>
void lcdline1(void);
void lcdline2(void);
void lcdline3(void);
void lcdline4(void);
void clearsreen(void);
void gsmlink(void);
void sms_send(void);
void disp_gpsdata(void);
void gps_check(void);
/*----serial communication functions prototypes declarations---*/
void USART_Init(void);
void USART_Transmit(unsigned char data );
void usart_puts(char *ptr);
void delay(unsigned char del);
/*----global variables declarations----*/
int i,k=0;
char d[75],start=0,rmcok=0,disp;
char gpsdata,cnt;
/*.....main function.....*/
int main(void)
{
DDRA =0xff;
DDRC =0xff;
DDRB =0xff;
DDRD =0xff;
lcdinit();
clearsreen();
lcdstring("VEHICLE TRACKING");
```



```

lcdline2();
lcdstring("USING GPS & GSM");
_delay_ms(1000);
clearscreen();
USART_Init();
_delay_ms(500);
gsmlink();
_delay_ms(1000);
lcdline1();
lcdstring("GSM initilizing");
_delay_ms(1000);
/*usart_puts("AT+CMGS=");
USART_Transmit(0x22);
usart_puts("8985754202");
USART_Transmit(0x22);
USART_Transmit(0x0d);
usart_puts("TIME:");
USART_Transmit(0x1A); */
k=0;
while(1)
{
disp_gpsdata();
PORTA =dat;
sbi(PORTB,LCD_RS);
cbi(PORTB,LCD_RW);
sbi(PORTB,LCD_EN);
_delay_us(10);
cbi(PORTB,LCD_EN);
}
/*****/
void lcdstring(char *str)

```

```

{
while(*str)
{
lcddata(*str);
str++;
}
}
/*.....lcd display routine function.....*/
void lcdline1(void)
{
lccmd(0x80);
}
void lcdline2(void)
{
lccmd(0xc0);
}
void lcdline3(void)
{
lccmd(0x94);
}
void lcdline4(void)
{
rmcok=0;
disp=1;
}
}
}
void usart_ puts(char *ptr)
{
while(*ptr)
{
USART _Transmit(*ptr);
}
}
}

```

```

ptr++;
}
i=0;
}
/*****/

void USART_Transmit( unsigned char data )
{
while ( !( UCSRA & (1<<UDRE)) );
UDR = data;
}
/*****/

void disp_gpsdata(void)
{
_delay_ms(100);
clearscreen();
if(disp==1)
{
//cli();
disp=0;
SREG = 0x00;
_delay_ms(1000);
/* //lcdline1()
delay_ms(20). {
{
// lcdstring("TIME:"); //hrs
for(k=5;k<=6;k++)
{
//lcddata(d[k]);
}
//lcdstring(":");
for(k=7;k<=8;k++)

```

```

{
//lcddata(d[k]);
}
//lcdstring(":");
for(k=9;k<=10;k++)
{
//lcddata(d[k]);
}*/
lcdline1();
lcdstring("LON:");
for(k=17;k<=27;k++)
{
lcddata(d[k]);
}
lcdline2();
lcdstring("LAT:");
for(k=29;k<=40;k++)
{
lcddata(d[k]);
}
//lcdline4();
//lcdstring("DATE:");
for(k=50;k<=55;k++)
{
//lcddata(d[k]);
}
cnt++; //sei();
_delay_ms(1000);
k=0;
_delay_ms(1000);
_delay_ms(1000);

```

```

_delay_ms(1000);
sms_send();
SREG = 0x80;
}
}
/*****/

void gps_check(void)
{
if(gpsdata=='R')
{
d[k]=gpsdata;
k++;
}
if( (d[0]=='R')&( gpsdata=='M'))
{
d[k]=gpsdata;
k++;
}
if((d[0]=='R')&(d[1]=='M')& (gpsdata=='C'))
{
d[k]=gpsdata;
k++;
rmcok=1;
}
}
/*****linking GSM to AVR*****/

void gsmlink(void)

```

```

usart_puts("AT"); USART_Transmit(0x0D); _delay_ms(20);
clearscreen();lcdline1(); lcdstring("AT");
usart_puts("ATE0"); USART_Transmit(0x0D); _delay_ms(20);
clearscreen();lcdline1(); lcdstring("ATE0");
usart_puts("AT+CSMS=0"); USART_Transmit(0x0D); _delay_ms(20);
clearscreen();lcdline1(); lcdstring("AT+CSMS=0");
usart_puts("AT+IPR=9600"); USART_Transmit(0x0D); _delay_ms(20);
clearscreen();lcdline1(); lcdstring("AT+IPR=9600");
usart_puts("AT+CMGF=1"); USART_Transmit(0x0D); _delay_ms(20);
clearscreen();lcdline1(); lcdstring("AT+CMGF=1");
usart_puts("AT&W"); USART_Transmit(0x0D); _delay_ms(20);
clearscreen();lcdline1(); lcdstring("AT&W");
usart_puts("AT+CNMI=2,1,0,0,0"); USART_Transmit(0x0D); _delay_ms(20);
clearscreen();lcdline1(); lcdstring("AT+CNMI=2,1,0,0,0");
}
/*****SIM DETAILS*****/
void sms_send(void)
{
i=0;
k=0;
usart_puts("AT+CMGS=");
USART_Transmit(0x22);
usart_puts("8985754202");
USART_Transmit(0x22);
USART_Transmit(0x0d);
usart_puts("TIME:"); //hrs
for(k=5;k<=6;k++)
{
USART_Transmit(d[k]);
}
USART_Transmit(0x3a); //min

```

```

for(k=7;k<=8;k++)
{
USART_Transmit(d[k]);
}
USART_Transmit(0x3a); //sec
for(k=9;k<=10;k++)
{
USART_Transmit(d[k]);
}
USART_Transmit(0x0D);
usart_puts("LONGITUDE:");
USART_Transmit(0x0D);
for(k=17;k<=27;k++)
{
USART_Transmit(d[k]);
}
USART_Transmit(0x0D);
usart_puts("LATITUDE:");
USART_Transmit(0x0D);
for(k=29;k<=40;k++)
{
USART_Transmit(d[k]);
}
USART_Transmit(0x0D);
usart_puts("DATE:");
USART_Transmit(0x0D);
for(k=53;k<=58;k++){
USART_Transmit(d[k]);
}
USART_Transmit(0x1A);
clearscreen();

```

```
lcdstring(" MSG SENT");  
k=0;  
}
```