

---

# A fault analysis of 11kv distribution system (a case study of ado Ekiti electrical power distribution district)

Kehinde Olusuyi<sup>1</sup>, Ayodele Sunday Oluwole<sup>1</sup>, Temitope Adefarati<sup>2</sup>,  
Adedayo Kayode Babarinde<sup>2,\*</sup>

<sup>1</sup>Department of Physical Planning unit, Federal University, Oye Ekiti, Nigeria

<sup>2</sup>Department of Electrical/Electronic Engineering, Faculty of Engineering and Technology, Federal University, Oye Ekiti, Nigeria

## Email address:

kehinde.olusuyi@fuoye.edu.ng (K. Olusuyi), sunday.oluwole@yahoo.com (A. S. Oluwole),

temitope.adeferati@yahoo.com (T. Adefarati), dbabarinde@gmail.com (A. K. Babarinde)

## To cite this article:

Kehinde Olusuyi, Ayodele Sunday Oluwole, Temitope Adefarati, Adedayo Kayode Babarinde. A Fault Analysis of 11kv Distribution System (A Case Study of Ado Ekiti Electrical Power Distribution District) *American Journal of Electrical Power and Energy Systems*. Vol. 3, No. 2, 2014, pp. 27-36. doi: 10.11648/j.epes.20140302.13

---

**Abstract:** The aim of this research work is to carry out fault analysis of 11KV distribution power system. Electric power is an essential facilitator for sustainable development of the modern nation state. While Nigeria is reported to suffer from severe shortages of electric power the condition of some of its newer constitutional units are unknown. In this work, electric power infrastructure and energy availability is studied for Ado-Ekiti, the principal economic and political hub of Ekiti State. During the study, the condition of all relevant equipment for power distribution at the 11 kV level was assessed. Power availability was also considered by collecting necessary data that had to do with energy supplied, faults and other outages. It was discovered that the distribution lines were in a rather poor state with as many as 25% of the poles not meeting a condition of "goodness", 33% of cross-arms being broken or unsatisfactory, about 10% of the insulators defective and almost 40% of the span not complying with standards. Hence this work presents a research on fault analysis of Ado Ekiti distribution power system.

**Keywords:** Distribution System, Over-current, Feeder, Earth Fault, Differential Fault, Ring Main

---

## 1. Introduction

The predominant factor distinguishing modern man from his ancestors is the ability to efficiently manage energy. In recent times electric power has become the most ubiquitous form of energy used for production, recreation, control and for carrying out most activities because of the ease with which it can be produced, transported and converted to various applications. Gordon Clapp, a former General Manager of the Tennessee Valley Authority (U.S.A) once said- "If you would destroy a region, you destroy its power supply. If you would hold a region to a lower standard of living, you can do it by placing a limit on its supply of electric power" (Uwaifo, 1994). Given its benefits to mankind, it was not long before electricity was regarded as an infrastructure, i.e. a basic necessity for man's socioeconomic well-being. It is now universally accepted that the social and economic factors which define the level of prosperity, are highly correlated with the level of demand for electric power.

Ado Ekiti is an agrarian town in the southwestern part of Nigeria. The town lacks many infrastructures which is common in most of the developing countries. One of these infrastructures is the poor state of electric power distribution. Electric Power distribution system in Ado Ekiti is something of a major concern. There are more outages than uninterrupted power supply in most parts of the state all the year round.

It is a known fact that electricity plays a dominant role in the socioeconomic development of any community. In view of the foregoing, this project seeks to identify the problems militating against regular, good quality electric power supply in the Ado Business district of Ekiti-State with a view to proffering solutions and suggestions where necessary. This is to improve the socioeconomic life of Power Holding Company of Nigeria (PHCN)'s customers in the state. Given this unsatisfactory state of affairs and the lack of comprehensive studies to formally guide the development of electric power in the state, there is a dire need for an assessment of the Ekiti-state electric power distribution with

a view to quantifying the availability of electric power and examining some of the physical factors that may contribute to the poor state of electric power infrastructure so that remedial suggestions may be proffered for improved system performance. It is in the light of this situation that this research has been conceived so as to provide useful information of the present condition from which rational and well-thought out improvements can be planned and implemented. Having analyzed the performance evaluation of Ado Ekiti power system, this paper provides all the expedient solutions to enhance reliability and availability of power supply in Ado Ekiti Power Distribution District.

## 2. Research Problem

The main research objective addressed in this project is to carry out an assessment of the electric power distribution system in the Ado district of Ekiti-State with a view to identifying and quantifying important parameters that can provide concise description of the state of electric power.

## 3. Objectives of the Research

The objectives of this research study are:

- i. To collate relevant information about the physical conditions of the electric power distribution system in the Ado district of Ekiti-State.
- ii. To create a database of faults experienced between 2001 and 2009 on the distribution network in the district and to carry out an analysis of the faults.
- iii. To study the quality of power and assesses the performance of the network between 2009 and 2010 by calculating useful indices of performance.

## 4. Elements of Electric Power Distribution

An electrical power system consists of all generating stations (hydro, thermal, nuclear, etc.) with the associated step-up and step-down transformers, bus-bars and transmission lines, reactors, circuit breakers etc. An electric power system embraces the generating, transmitting and distributing systems. The electricity industry in Nigeria has grown progressively more complex from a number of relatively small isolated power stations in the early 1950s to an integrated power system which the National Electric Power Authority (NEPA) now referred to as the Power Holding Company of Nigeria (PHCN) runs today (Aduloju, 2003).

An integrated power system may be defined as a system in which all sources of power generation and all loads are physically interconnected in such a way that power can flow from any source to any load. Since such systems may be dispersed over great distances between loads and the stations, supplies are routed through a high or extra-high voltage network known as the transmission system or the grid.

Energy flows from the generating stations through the transmission systems to the various loads or customers. Transmission lines are used to transfer power economically over long distances usually at a voltage not suitable for the customers. At the load distribution points, power is supplied in bulk at a lower voltage to selected number of points or substations.

### 4.1. Distribution System

At tertiary substations, the voltage is stepped down from 33 kV to 11 kV. Subsequently, power is transported through primary distribution lines (also called feeders) to distribution substations. Distribution substations are situated at convenient locations close to the centre of gravity of some components of the load. Secondary distribution lines (also called distributors) emanating from the distribution substation, deliver the power to the consumers (domestic, commercial, industrial etc.) (Riana et al, 1985).

### 4.2. Components of Electric Power Distribution System

Electric power distribution system consists of the substation equipment and the overhead distribution lines with their accessories. These components include transformers, conductors, line supports, circuit breakers, Ring Main Units (RMUs), cross arms, guy assemblies, isolators, fuses, lightning arresters, measuring instruments and relays.

### 4.3. Distribution Faults

All electricity industries worldwide experience power-delivery problems. Faults can be very destructive to power system. A great deal of study and development of devices and design of protection schemes have resulted in continual improvement in the prevention of damage to transmission lines, equipment and interruptions in generation following the occurrence of a fault (Stevenson, 1982).

The following types of fault exist in the primary substation of the distribution system:

- (i) Over-current: This fault occurs very often when there exists a short circuit on the system or anytime there is bridging of the phases of the overhead lines.
- (ii) Earth Fault: This fault exists anytime the line conductor cuts or snaps and drops on the steel cross arm or on the ground. Earth fault could also occur when a fresh tall tree touches the overhead lines.
- (iii) Differential Fault: This fault exists when there is a problem within the transformer windings and/or the inter-connecting cable between the transformer and the breakers. The differential fault normally results in the flow of unbalanced current in the transformer windings. When an unbalanced current (fault current) flows through the differential relay windings, the relay senses the fault and sends a tripping signal to the circuit breaker which automatically isolates the transformer for safety before it gets burnt as a result of circulating

unbalanced current.

- (iv) Buchholz Fault: This fault normally occurs inside an operating transformer in the form of insulation puncture, shorted windings, poor contact or sparks due to poor grounding with the evolution of gases resulting from the decomposition of oil or the insulation.

In the Distribution and Marketing subsector of the Power Holding Company of Nigeria(PHCN),the faults are as follows:-

1. H.T line faults, caused by 33 kV and 11 kV lines, broken and leaning poles, disc and pin insulators, cross arms and cables.
2. Substation faults, caused by distribution transformers, H.T cables (from D-fittings to transformer), L.T cables (incomer and upriser cables), feeder pillar, D-fittings.
3. L.T lines faults, caused by broken poles, shackle insulators, wire cut (causing live wire to be on the ground).

**4.4. Most Likely Causes of Fault on H.T and L.T Overhead Lines**

H.T and L.T overhead line faults are visible through proper inspection along the line. For an overhead line feeder or feeder comprising both underground cable and overhead line, earth fault on the overhead line portion of the feeder could be caused by one or more of the following:

1. Cracked Strain or Disk Insulator  
If the insulator on which the conductor is held cracks, the current will leak to earth through the channel iron or cross arm via the concrete pole or tower to the ground to cause earth fault.
2. Cut Jumper  
When a jumper or jumpers cut and rest on the channel iron, an earth fault results. A jumper that cuts and bridges another line will result into over-current fault only.
3. Cracked Lightning Arrestor pilot insulators mounted on iron cross arm.

**5. The Ado- Ekiti District of the PHCN**

The 33/11 kV injection substation located at Bashiri which services Ado-Ekiti is fed from 132/33KV substation Omisanjana. It has two power transformers rated at 7.5 MVA and 15 MVA with each transformer having two feeders named as follows:

*Table 1. 33/11KV injection substation and its feeders*

Feeder	Area	Distance
Feeder I	Ajilosun / GRA feeder	7.325 km
Feeder II	Bashiri / Iyin / Igede feeder	17.2 km
Feeder III	Okesha / Federal Housing feeder	17.7 km
Feeder IV	Adebayo / Opopogbooro feeder	9.85 km

The 7.5 MVA transformer input is designated incomer I which feeds Bashiri / Iyin / Igede (feeder II) and Okesha / Federal Housing (feeder III) while the 15 MVA transformer input is designated incomer II and feeds Ajilosun / GRA

(feeder I) and Adebayo / Opopogbooro (feeder IV).

**5.1. Study Process for Assessment**

The process of study of the assessment started with the evaluation of the physical condition of the distribution system with specific reference to the type and size of conductors, pole supports, spans and clearances, cross-arms, type of insulators and route length. A study of the operational and failure features of the network in terms of availability and quality of power, types of fault and frequency of occurrence of faults.

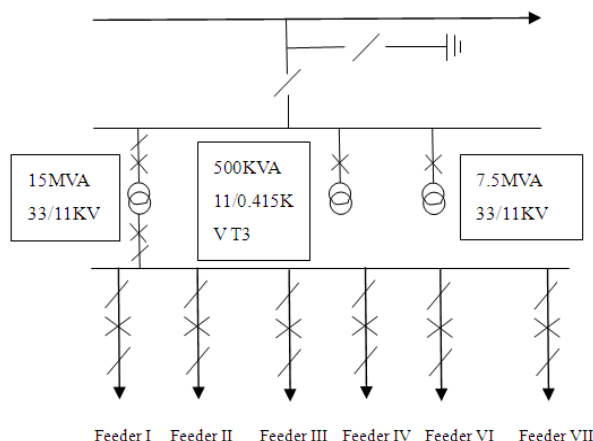

*Fig 1. Schematic diagram of Ado Ekiti 33/11Kv injection station.*

**5.2. Failure Rate Analysis**

Hourly readings of the four feeders at Ado main station for 2009 and 2010 were obtained for analysis using the Microsoft Excel package. Various characterizations of hours of blackouts, load shedding, power availability, fault conditions and outages were then distilled into statistical representations. From these the failure rates were analyzed.

**5.3. Load Curve Studies**

Average load values for the four feeders were obtained using further statistical functions of the excel package. The values were then used to obtain load curves from which other analyses were carried out.

**6. Results and Observations of the Feeder Network in the Ado District**

Inspection of the overhead lines revealed that in Ekiti-State, the supporting structures for the distribution systems are predominantly either reinforced concrete or wooden poles with a few steel towers, similarly with either wooden or steel cross-arms. The abundance of trees in Ekiti-State’s forest makes the use of wood as supporting structures very economical. Most of the ‘right-of-ways’ in Ekiti-State pass through the forest due to the nature and topography of the state. However, the distribution networks were characterized by leaning poles or crooked structures,

shattered insulators, broken or decayed cross-arms and vegetation encroachment.

**6.1. Component Analysis in the Ado District**

The following tables and figures provide a graphic representation of the physical state of the components of the 11kV network in Ado district. The poor state of the lines accounts for the incessant outages and faults observed. The tables and figures are as follow:



**Fig 2.** Wooden Pole with a Broken Wooden Cross-Arm.



**FIG 3.** 11Kv line with a Slanting cross arm.



**Fig 4.** 11kV Line with a cross arm.



**Fig 5.** 11KV line without a broken cross arm.

11kV/415V Ado Ekiti Distribution Route

**6.2. Estimation of Load Curves for the Ado District**

Daily hourly load readings on the four feeders emanating from the Ado main injection substation namely Adebayo, Ajilosun, Bashiri and Okesha feeders for 2009 and 2010 were obtained from which load curves for the different feeders were estimated. This was done with the use of the Microsoft Excel package. Average hourly readings for a particular time of the day were obtained for the feeders

which were then used to obtain the load curves. The load curves for the feeders for 2009 and 2010 are shown below:

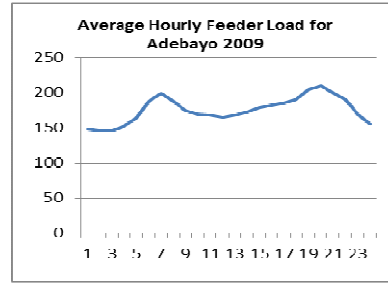

**Figure 6.** Average Hourly Feeder Load Curve for Adebayo, 2009.

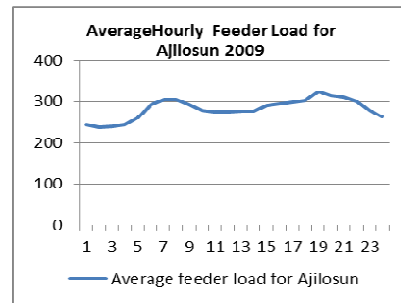

**Figure 7.** Average Hourly Feeder Load Curve for Ajilosun, 2009.

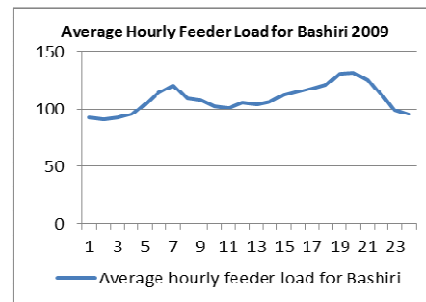

**Figure 8.** Average Hourly Feeder Load Curve for Bashiri, 2009.

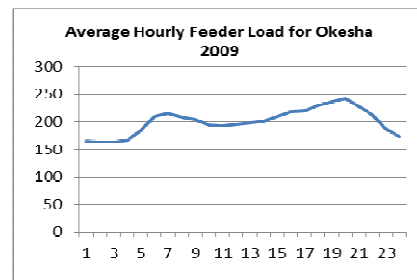

**Figure 9.** Average Hourly Feeder Load Curve for Okesha, 2009.

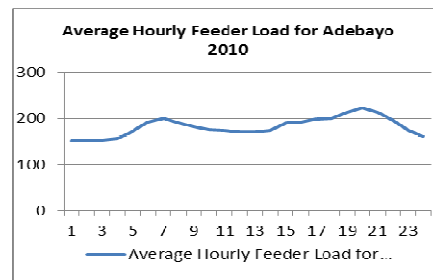

**Figure 15.** Average Hourly Feeder Load for Adebayo, 2010.

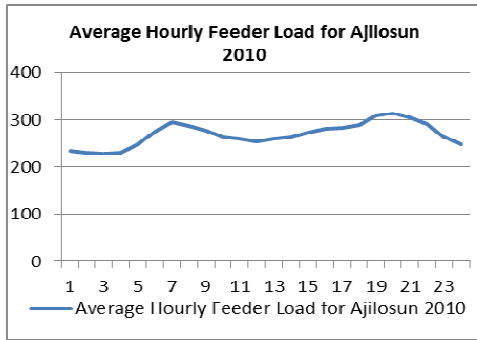

Figure 16. Average Hourly Feeder Load for Ajilosun, 2010.

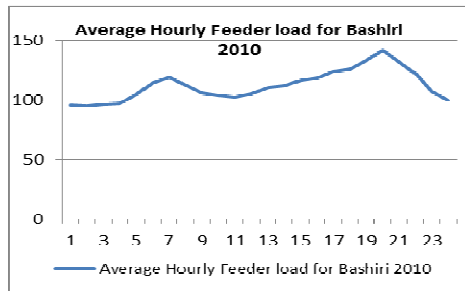

Figure 10. Average Hourly Feeder Load Curve for Bashiri 2010.

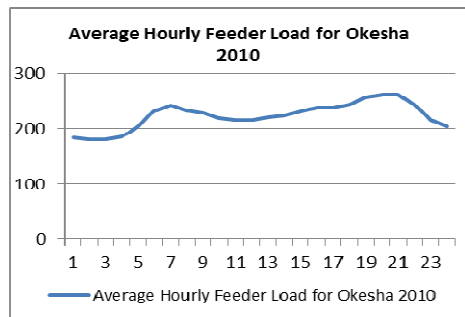

Figure 11. Average Hourly Feeder Load curve for Okesha, 2010.

**6.3. Analysis and Assessment of the Performance of the EPDS in the Ado District**

In order to assess the performance of the distribution network of the Ado district, daily hourly load readings for two consecutive years – 2009 and 2010 - were obtained from the Power Holding Company Of Nigeria (PHCN), Ado-Ekiti and distilled into a spreadsheet database using the Microsoft excel package from which further statistical and stochastic analyses were performed. The daily hourly load readings for the four feeders namely Adebayo, Ajilosun, Bashiri and Okesha feeders for 2009 and 2010 were separately analyzed so as to compare their performances.

The various parameters for analysis include the following: Duration of Supply, Duration of Blackout, Duration of Load shedding, Duration of Earth Fault, Duration of Over-current Fault, Duration of Over-current and Earth Fault, Duration of Outage, Duration of Fault and Duration of Strike. For instance in 2009, out of 8760 hours in the year the Adebayo feeder recorded 2296 hours of power supply, 3509 hours of blackout, 2123 hours of load shedding, 158 hours of earth fault, 473 hours of over-current fault, 147 hours of both earth

fault and over-current fault, 22 hours of outage and 32 hours of miscellaneous fault. The following figure shows the contributions of the various parameters. It will be observed that power was available for only 26% of the time on Adebayo feeder while it is either having black-outs accounting for 40% of the time or on load shedding representing 24% of the time. This service availability has placed a limit on the quality of life and a level of socio-economic activities that can take place with public power supply.

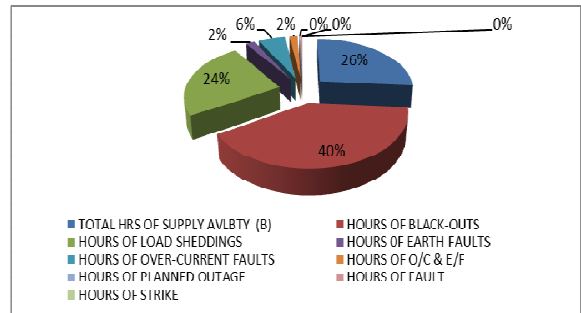

Figure 12. Parameters on Adebayo Feeder, 2009.

Similarly, in this same year 2009 and on Ajilosun feeder, there were 2891 hours of power supply, 3145 hours of blackout, 2070 hours of load shedding, 75 hours of earth fault, 337 hours of over-current fault, 2 hours of over-current and earth faults, 56 hours of outage and 184 hours of miscellaneous fault. The figure below shows the contributions of the parameters.

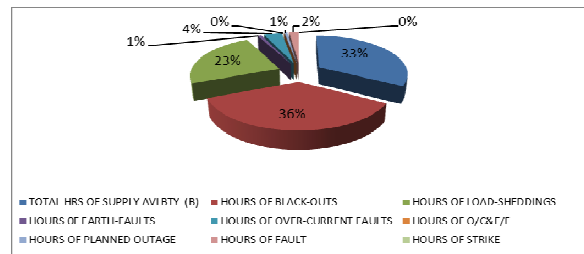

Figure 13. parameters on Ajilosun Feeder, 2009.

In this same vein, in 2009 and on Bashiri feeder, there were 2932 hours of power supply, 3090 hours of blackout, 2364 hours of load shedding, 241 hours of earth fault, 118 hours of over-current fault, 3 hours of over-current and earth fault and 12 hours of outage.

The figure below shows the contributions of the parameters:

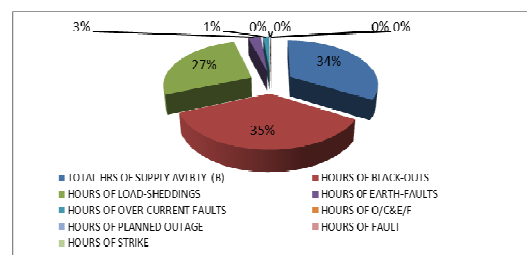

Figure 14. Parameters for Bashiri Feeder, 2009.

Also, for Okesha feeder, there were 2265 hours of power supply, 3258 hours of blackout, 3255 hours of load shedding, 232 hours of earth fault, 231 hours of over-current, 158 hours of over-current and earth faults, 91 hours of outage and 270 hours of miscellaneous fault. The figure below shows the parameters for the feeder.

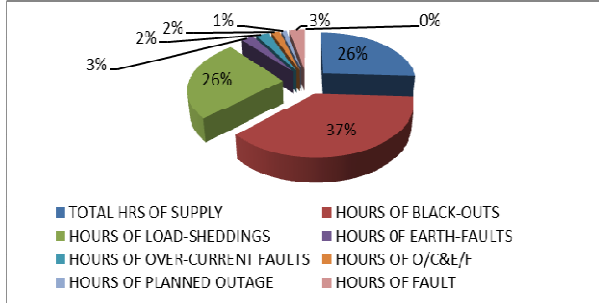

Figure 15. Parameters for Okesha Feeder, 2009

In the same vein, in 2010 and on the Adebayo feeder, there were 2343 hours of power supply, 2682 hours of blackout, 2956 hours of load shedding, 74 hours of earth fault, 343 hours of over-current, 187 hours of over-current and earth fault, 27 hours of planned outage, 20 hours of outage, 90 hours of miscellaneous fault and 38 hours of strike action by PHCN staff. The figure that follows shows the various contributions of the parameters.

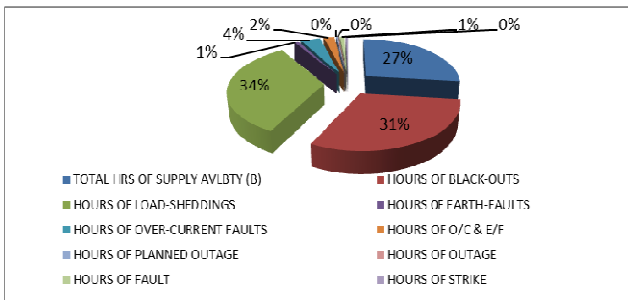

Figure 16. Parameters on Adebayo feeder, 2010

Similarly, for Ajilosun feeder in 2010, there were 2813 hours of power supply, 2592 hours of blackout, 2669 hours of load shedding, 118 hours of earth fault, 258 hours of over-current fault, 60 hours of outage, 213 hours of miscellaneous fault and 37 hours of strike action by PHCN staff. The figure below gives a graphical representation of the performance for the feeder.

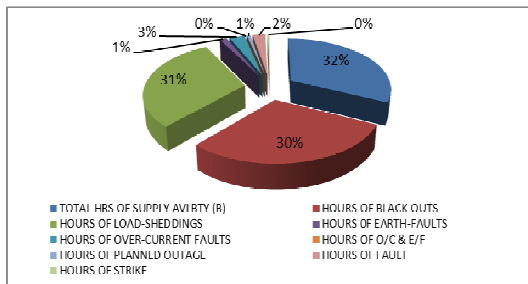

Figure 17. Parameters on Ajilosun feeder, 2010

For the Bashiri feeder in 2010, there were 2878 hours of power supply, 2430 hours of blackout, 2948 hours of load shedding, 218 hours of earth fault, 79 hours of over-current fault, 17 hours of over-current and earth faults, 30 hours of outage, 123 hours of miscellaneous fault and 37 hours of strike action by PHCN staff. The figure that follows shows the graphical representation for the feeder.

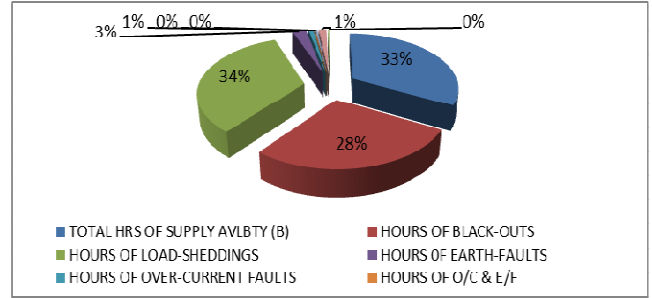

Figure 18. Parameters on Bashiri feeder, 2010

And for Okesha feeder in 2010, there were 2465 hours of power supply, 2325 hours of blackout, 3188 hours of load shedding, 89 hours of earth fault, 211 hours of over-current fault, 127 hours of over-current and earth faults, 50 hours of outage, 269 hours of miscellaneous fault and 36 hours of strike action by PHCN staff. The figure below shows the performance of the feeder.

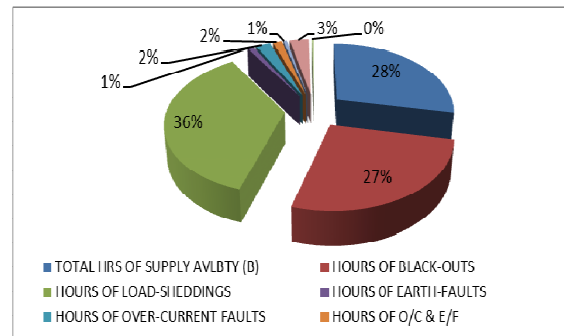

Figure 19. Parameters on Okesha feeder, 2010

Further analyses of the performance of the four feeders with respect to the parameters yield the following. This is aimed at comparing the performance of the four feeders in relation to the parameters for years 2009 and 2010. The dynamics that were analyzed are outages either due to faults or planned, black-out and load shedding and supply.

A comparative analysis of power supply to the four feeders is presented in the figure below.

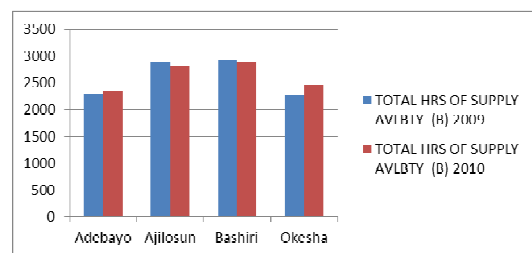

Figure 20. Comparison of Total Hours of Supply

Similarly, comparisons of the performance of the four feeders in Ado Figure 29: Total Hours of Black-out injection station for total hours of black-out, load shedding, earth fault, over-current faults are summarized in the charts below:

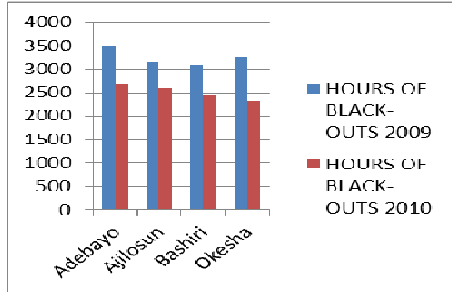

Figure 21. Total Hours of Load Shedding

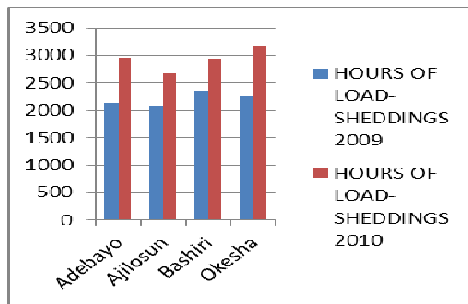

Figure 22. Total Hours of Earth Fault

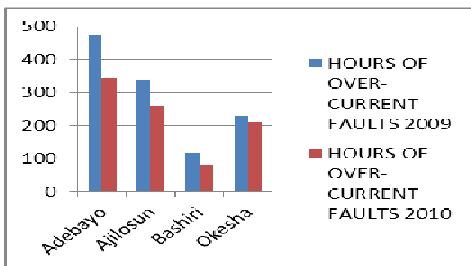

Figure 23. Total Hours of overcurrent Fault

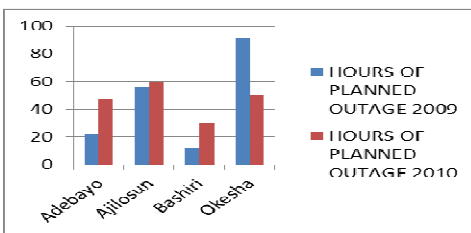

Figure 24. Total Hours of Over-current

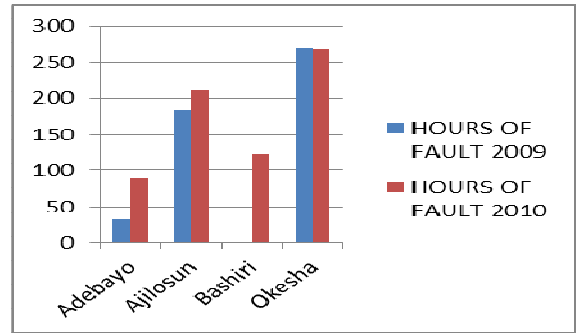

Figure 33. Total Hours of Fault

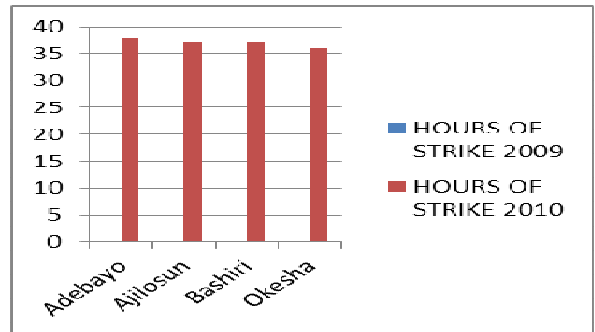

Figure 26. Total Hours of Strike

In order to compare the energy supplied to the feeders, average feeder load readings for the feeders were calculated using values generated from the Excel database in combination with total hours of power supply to obtain the kilo-volt-ampere-Hour values for each feeder. The tables below summarize the results for the four feeders.

Table 2. Average Feeder Loads.

Average Annual Feeder Load Reading					
Feeder	Year	2009		2010	
		Feeder Load (A)	Feeder Load (A)	Total Hrs of Suply 2009	Total Hrs of Suply 2010
Feeder	Adebayo	176	183	2296	2343
	Ajilosun	283	265	2891	2813
	Bashiri	109	112	2932	2878
	Okesha	201	223	2265	2465

Table 3. Feeder kilo-volt-ampere-Hours.

kVAhr	2009	2010
Adebayo	7686023	8148185
Ajilosun	15572850	14208854
Bashiri	6080026	6156897
Okesha	8655663	10489541
SUM	37994561	39003476

The various contributions of the energy supplied to the four feeders are depicted in the figure below.

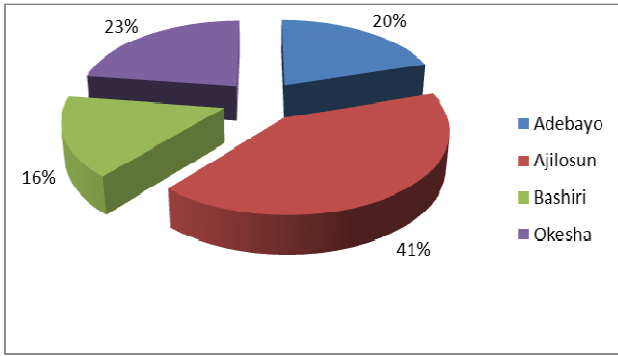

Figure 25. Energy Supplied to the Four Feeders.

6.4. Analysis of Faults Experienced between 2001 and 2009 in Ado-Ekiti District

Faults experienced on the 33kV and 11kV distribution networks of Ado district between 2001 and 2009 were obtained from the Power Holding Company of Nigeria PLC (PHCN), Ado Business District and distilled into a spreadsheet database using Microsoft Excel. The database contains details of types of fault cleared on a monthly basis for the period 2001 and 2009 on both the 11kV and 33kV networks. It is however to be noted that the data are aggregates of faults cleared on a yearly basis. These details are available in the appendix.

Similarly, number of 11kV earth faults cleared between the period 2003 and 2009 is shown below.

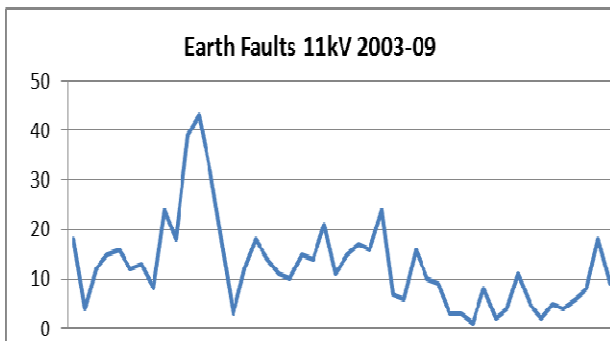
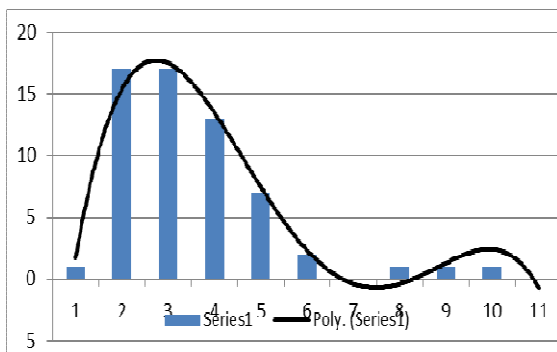

Figure 26. Earth Faults on 11kV Network between 2003 and 2009.

The frequency distribution for the earth faults observed on the 11kV network in Ado district between 2003 and 2009 is given in the figure below.



7. Discussions

7.1. Analysis of Feeder Performance

It will be observed that power was available for only 26% of the time on Adebayo feeder while it is either having black-outs accounting for 40% of the time or on load shedding representing 24% of the time. This is representative of the performance of the three other feeders with respect to service availability. This service availability has placed a limit on the quality of life and a level of socio-economic activities that can take place with public power supply in the areas being fed from these feeders.

7.2. Power Supply to Feeders

Over the two year period, there were marginal increases in total hours of power supply on Adebayo and Okesha feeders while there were marginal decreases in that of Ajilosun and Bashiri feeders.

7.3. Energy Supplied to the Four Feeders

From figure 4.43 in chapter four, it is seen that in 2009, the Ajilosun feeder has the greatest share of energy supplied with 41% of the total energy. This is followed by Okesha feeder with 23% of the supplied energy and then followed by 20% share by Adebayo feeder. The least energy is supplied to Bashiri feeder with just 16% of the total energy supplied. This same trend of distribution continued in 2010 although, with varying percentage contributions.

8. Conclusions

In the course of this project an engineering assessment of the electric power distribution system in the Ado district of Ekiti-State has been carried out. The assessment aimed at investigating the physical state of the distribution system, operational performance of the system in terms of determining hours of power supply, hours of black-out, hours of load shedding, hours of fault as well as obtaining probabilities of consecutive hours of power at any time of the day.

From the results obtained in chapter four of this thesis, it is seen that on an annual average basis Ekiti-State is experiencing erratic power supply as power may only be available in about just a third of a year. This is evident in the fact that power may only be available for three consecutive hours for 101 days at 2.00a.m on the Bashiri feeder, the highest value for the four feeders. The low value is attributable to poor supply from source of power, periods of load shedding, periods of fault as a result of the poor state of the lines and other outages whether planned or unplanned.

8.1. Recommendations

The following recommendations are hereby advanced so as to improve system performance of power distribution in Ekiti-State:

1. More attention should be paid to the maintenance of the



distribution network by the Power Holding Company of Nigeria (PHCN).

2. Government should vote more funds to infrastructural development of electric power distribution so that defective components can be replaced as soon as possible.

3. The radial configuration of the distribution network should be replaced with a ring network so that power can be supplied from alternative sources.

4. The right-of-ways should be adequately maintained in order to avoid interruptions on the network as a result of incidences of fallen trees and creepers. This will also make line tracing much easier.

---

## References

- [1] Adegboye, B.A. (1998): "Failure Analysis of the 11kV Primary Distribution Feeders" National Engineering Conference Series vol. 5 No. 1, pp47-52
- [2] Aduloju, A.O. (2003): "Electrical Power Systems" Evidence Nigeria Ventures, Ilorin, Nigeria
- [3] Akinsanya, O.A.(2005): "Electrical Power system in Ekiti-State Problems and Suggestions" Proceedings of 1st Engineering Forum, School of Engineering, The Federal Polytechnic, Ado- Ekiti on Capacity Building in Infrastructural Maintenance. Pp28-32
- [4] Allan, Ron and Billinton, Roy (2000): "Probabilistic Assessment of Power Systems" Proceedings of the IEEE, vol. 88, No. 2
- [5] Billinton, Roy and Allan N Ronald (1984): "Reliability Evaluation of Power Systems" London, England: Pitman Advanced Publishing Program, 1984.
- [6] Billinton, R and Allan R.N (1992): "Reliability Evaluation of Engineering Systems: Concepts and Techniques" Second Edition, New York: Plenum
- [7] Brass, D.F.S et al (1966): "Electric Power Distribution, 415V-33kV" E.O Taylor and G.A Boal (eds), London: Edward Arnold, p272 Brown, E Richard (1988): "Electric Power Distribution Reliability" Second Edition, New York: John Wiley & Sons
- [8] Brown, R.E, Gupta, S, Christie, R.D, Venkata, S.S and Fletcher, R (1996): "Distribution System Reliability Assessment Using Hierarchical Markov Modelling" IEEE Transactions on Power Delivery, vol. 11 No.4
- [9] Burke, J. James (1994): "Power Distribution Engineering-Fundamentals and Applications" Marcel Dekker, Inc
- [10] Da Silva, M.G, Rodrigues, A.B, de Castro, C.L.C, Neto, A.C, Moutinho, E.A, Neto, N.S.A and Cavalacante, A.B (2004): "Reliability Assessment of Distribution Networks in Brazil's northeast" 8<sup>th</sup> International Conference on probabilistic Methods Applied to Power Systems, Iowa State University, September 12-16
- [11] Davies, T (1984): "Protection of Industrial Power Systems" Pergamon Press.
- [12] Debs, A.S. (1988): "Modern Power Systems Control and Operation" New York: Kluwer Academic Publishers.
- [13] Desphande, M.V (1993): "Element of Electrical Power Station Design" Third Edition, Wheeler
- [14] Dorf, C Richard (2000): "The Electrical Engineering Handbook" Boca Raton: CRC Press LLC
- [15] Ette, A.I.I. (1993): "Facts and Fallacies about Lightning and Rain" Textflow Limited, Ibadan, Nigeria
- [16] Ewesor, P.O. (2003): "Practical Electrical Systems Installation- Work and Practice" Ambik Press Limited, Benin City
- [17] Fink, D.G and Beaty, H.W (1978): "Standard Handbook for Electrical Engineers" Eleventh Edition, New York: McGraw-Hill
- [18] Gonen, Turan (1986): "Electric Power Distribution System Engineering" International Edition, McGraw-Hill Book Company.
- [19] Gonen, T (1988): "Electric Power Transmission Engineering" New York: Wiley p.723\_
- [20] Green, A.E and Bourne, A.J (1972): "Reliability Technology" New York: Wiley-Interscience
- [21] Gross, C.A. (1986): "Power System Analysis" Second Edition. New York: Wiley
- [22] Gungor, B.R. (1988): "Power Systems" New York: Harcourt Brace Jovanovich
- [23] Gupta, B.R. (2005): "Power System Analysis and Design" Fourth Edition S. Chand & company Ltd.
- [24] Henley, E.J and Kumamoto, H (1991): "Probabilistic Risk Assessment-Reliability Engineering Design, and Analysis" New York: IEEE press
- [25] <http://hdrstats.undp.org/2008/>
- [26] "IEEE Transactions on Reliability" New York: Institute of Electrical and Electronics Engineers
- [27] Kjolle, Gerd and Sand, Kjell (1991): "REL RAD - An Analytical Approach for Distribution System Reliability Assessment" IEEE Transactions on Power Delivery, vol. 7, No. 2
- [28] Lewis, E.E (1987): "Introduction to Reliability Engineering" New York: John Wiley & Sons
- [29] Modigie, J.J. (2005): "Electricity Generation, Transmission and Distribution" Unpublished monograph, National Electric Power Authority
- [30] O'Connor, P.D.T (1985): "Practical Reliability Engineering" Third Edition. New York: John Wiley & Sons
- [31] Pansini, J. Anthony (1971): "Basic Electrical Power Distribution" Volume 1, revised second Edition, Hayden Book Company, Inc.
- [32] Pansini, J. Anthony, (1986): "Electrical Distribution Engineering" McGraw-Hill Book Company.
- [33] Pecht M. G and Nash F.R (1994): "Predicting the Reliability of Electronic Equipment" Proceedings of the IEEE, vol. 82 No. 7, 994-1004
- [34] Power Holding Company of Nigeria, Ado-Ekiti Business District, Annual Reports 2001-2009

- [35] Power Holding Company of Nigeria, Ado-Ekiti Business District, 11kV Daily Hourly feeder Loading Log book 2009-2010
- [36] Proceedings: "Annual Reliability and Maintainability Symposium" New York: Institute of Electrical and Electronics Engineers
- [37] Ramakumar, R (1993): "Engineering Reliability: Fundamentals and Applications" Englewood Cliffs, N.J.: Prentice-Hall
- [38] Riana, K.B., et al. (1985): "Transmission and Distribution of Electric Power" Tata McGraw-Hill Publishing Company Limited
- [39] Shooman, M.L (1990): "Probabilistic Reliability: An Engineering Approach" Second Edition.
- [40] Malabar, Fla: R.E Krieger Publishing Company Siewiorek, D.P and Swarz, R.S (1982): "The Theory and Practice of Reliable System Design" Bedford Mass: Digital Press
- [41] Stevenson, W.D. (1982): "Elements of Power System Analysis" 4th Edition, McGraw Hill International.
- [42] Sullivan, J Michael, Suddeth, B Noland, Vardell, Jerry and Vojdani (1996): "Interruption Costs, Customer Satisfaction and Expectations for Service Reliability" IEEE Transactions on Power Systems, vol. II, No.2
- [43] Trivedi, K.S (1992): "Probability and Statistics with Reliability, Queuing and Computer Science Applications" Englewood Cliffs, N.J.: Prentice-Hall
- [44] Uwaifo, S.O (1994): "Electric Power Distribution Planning and Development" Malthouse Press Limited.
- [45] Villemeur, A (1992): "Reliability, Availability, Maintainability and Safety Assessment, volumes I and II" New York: John Wiley & Sons
- [46] Weedy, B.M (1980): "Underground Transmission of Electric Power" New York: Wiley P294
- [47] Weedy, B.M (1987): "Electric Power Systems" New York: John Wiley & Sons
- [48] Weeks, W.L (1981): "Transmission and Distribution of Electric Energy" New York: Harper & Row p302
- [49] Woczynski, E, Billinton, R, and Wacker, G (1984): "Interruption Cost Methodology and Results – A Canadian Commercial and Small Industry Survey" IEEE Transactions on power Apparatus and Systems, vol. PAS-103, No. 2
- [50] Wood A.J and Wollenberg, B.F (1984): "Power Generation, Operation and Control" New York: John Wiley & Sons